

Fachada Estrutural

Fachada Semi-Estrutural

Fachada Muro Invertido

Fachada Milénio

Sistema Ergolux

Lâminas Quebra Sol

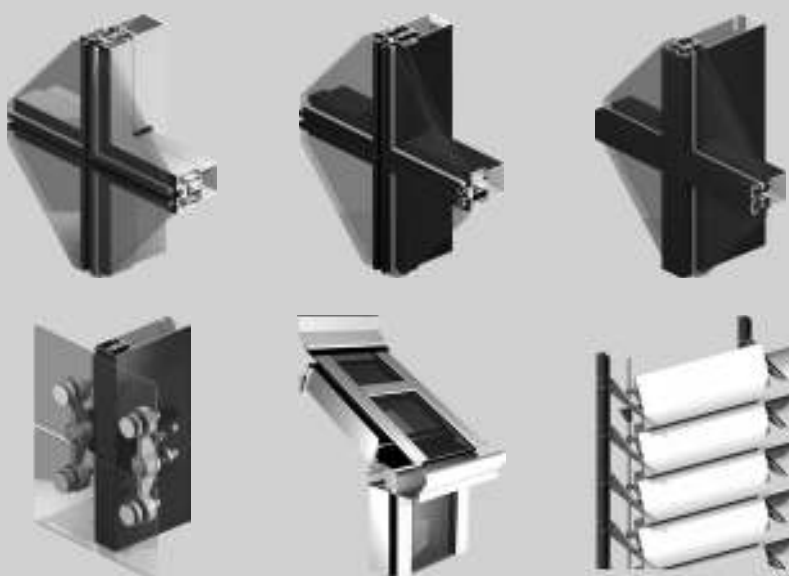

**Sistema**

**FL**



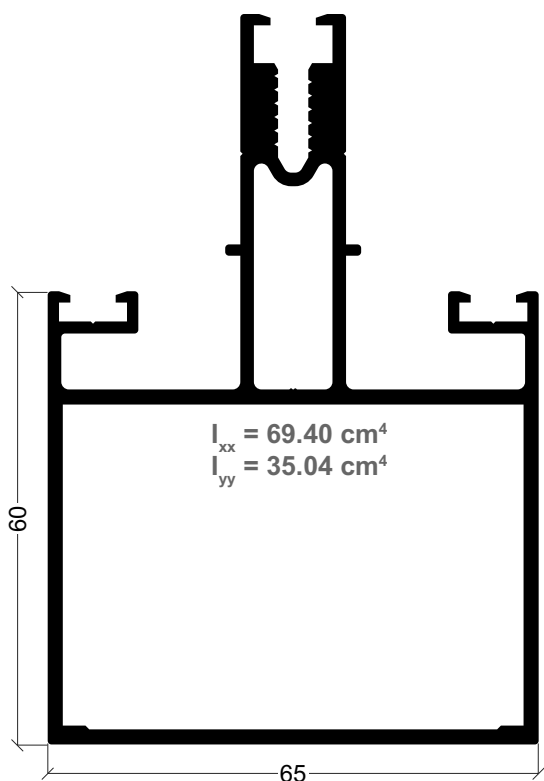

**FL-14**  
Montante de 60 mm

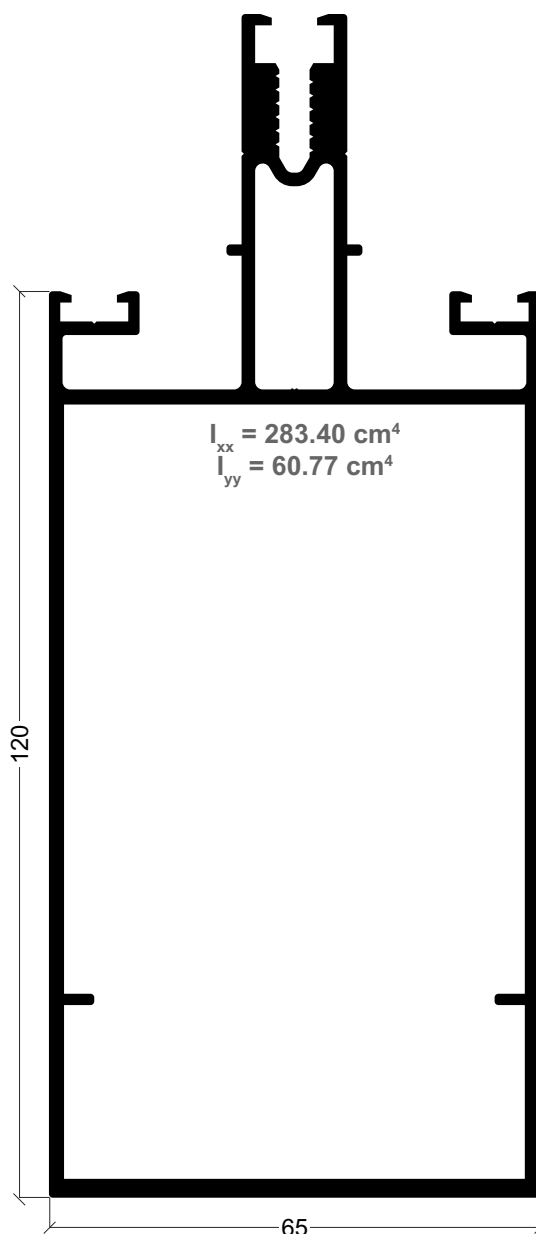

**FL-13**  
Montante de 120 mm

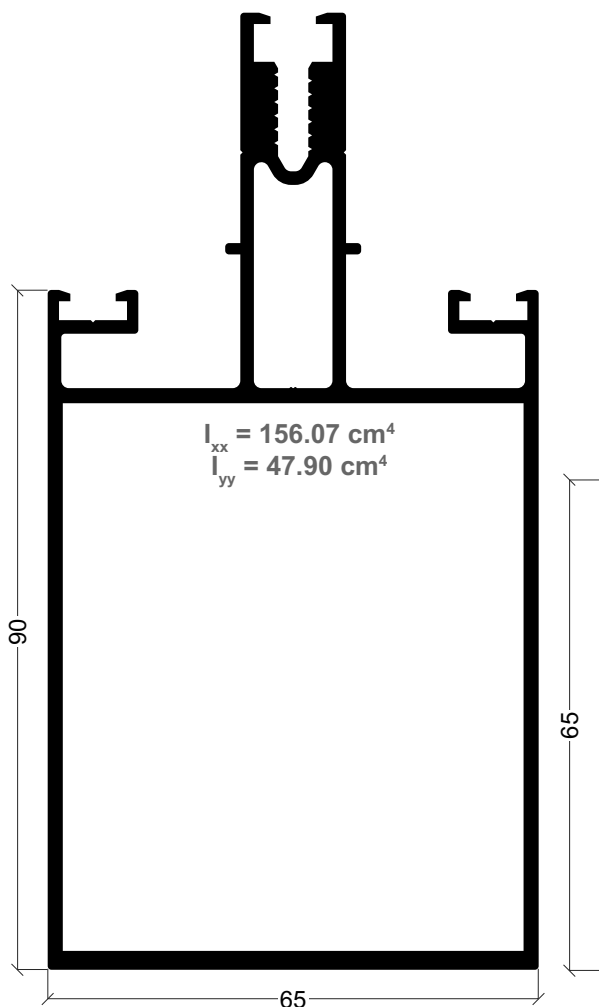

**FL-10**  
Montante de 90 mm

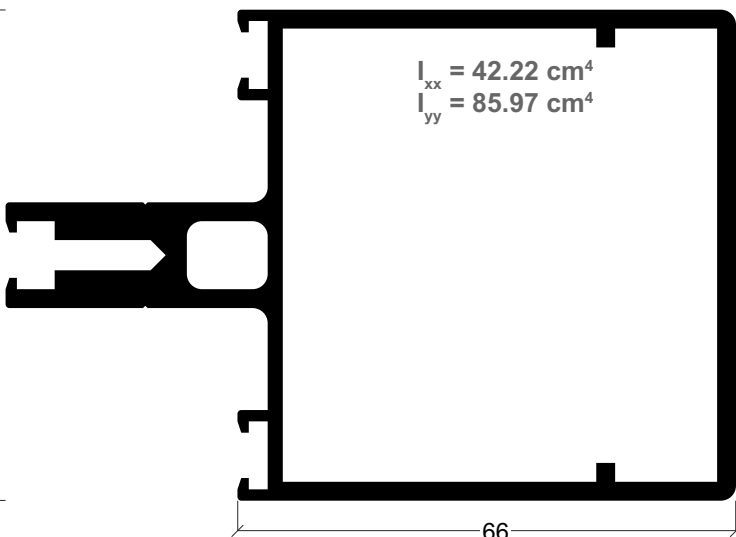

**FL-80**  
Travessa 66 mm

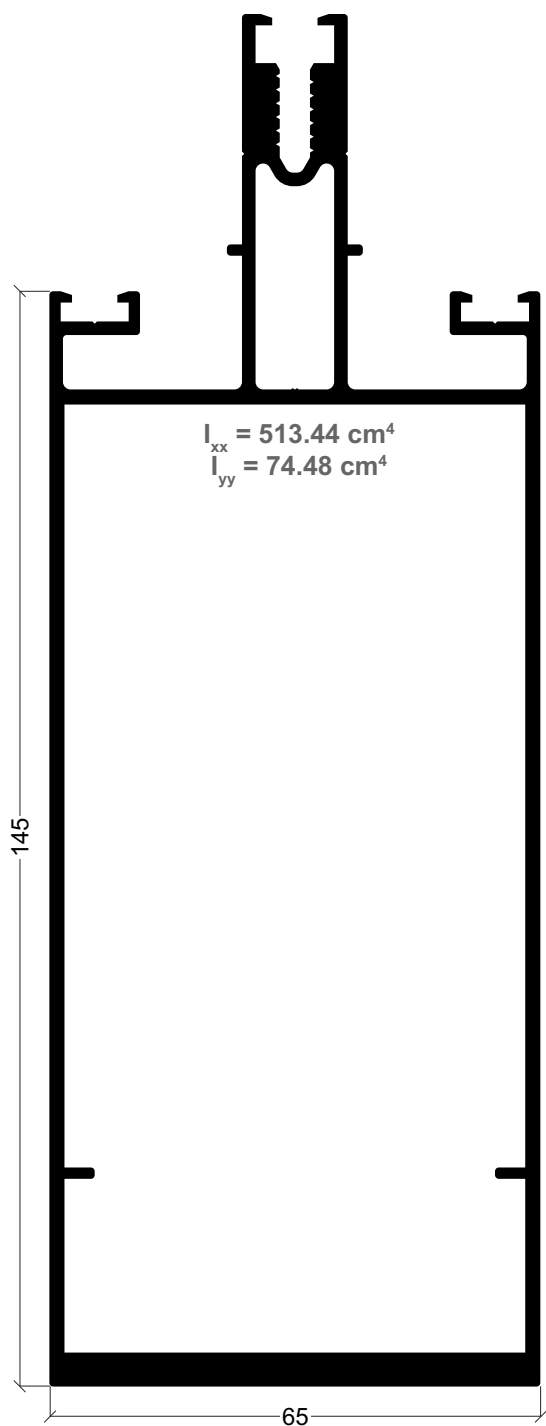

**FL-11**  
Montante de 145 mm

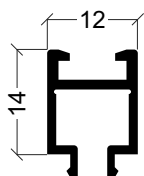

**FL-32**  
Suplemento

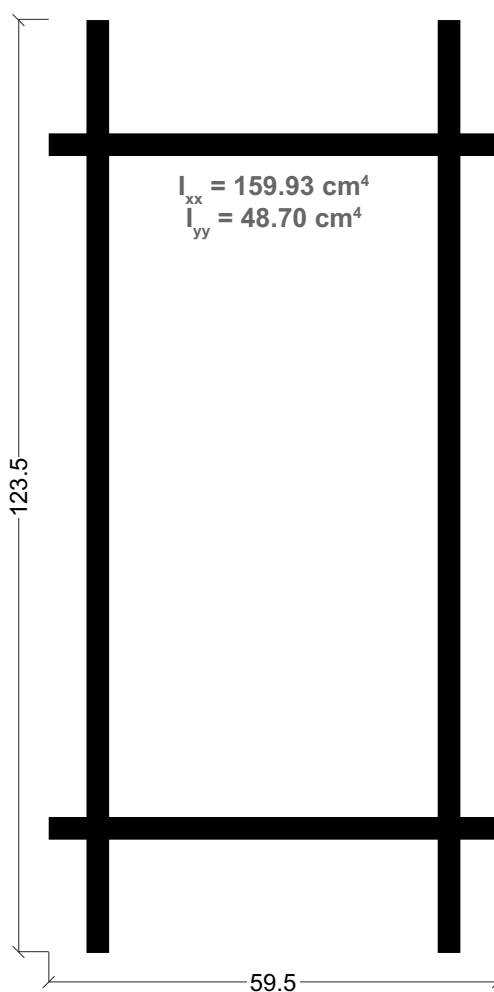

**FL-20**  
União de montantes

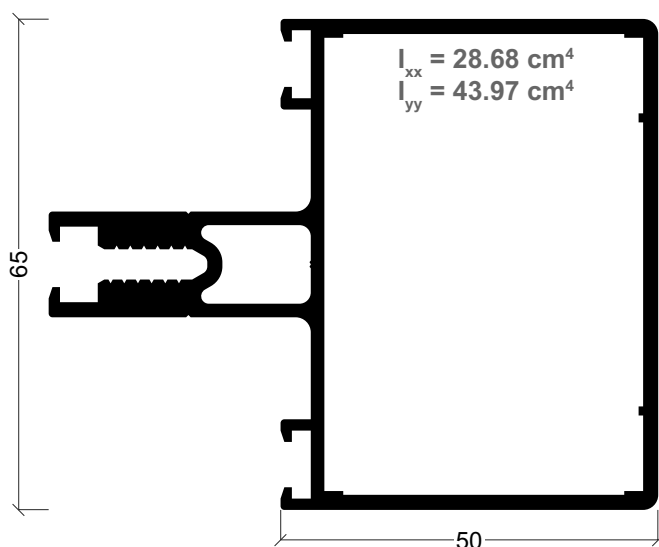

**FL-12**  
Travessa 50 mm

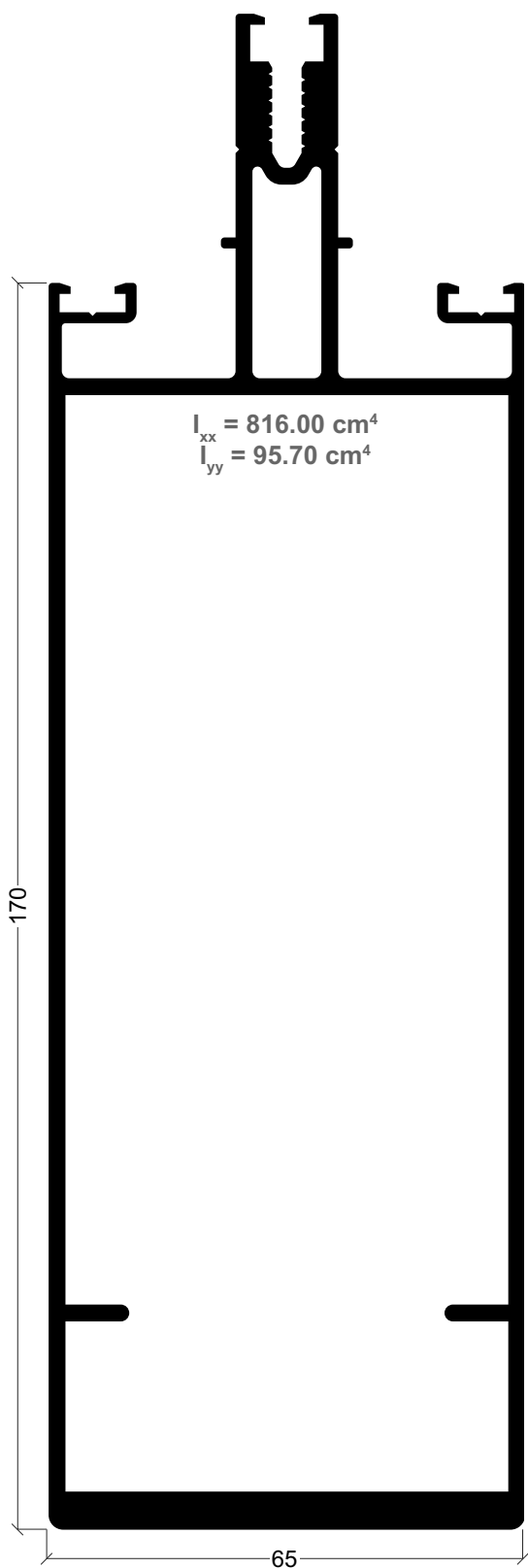

**FL-70**  
Montante de 170 mm

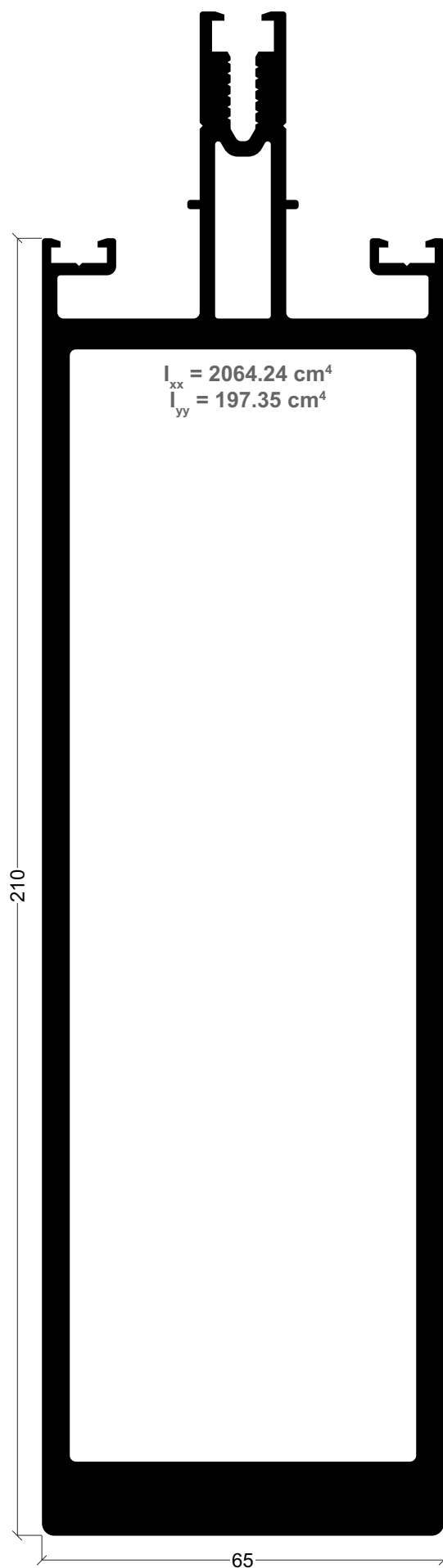

**FL-34**  
Montante de 210 mm

376

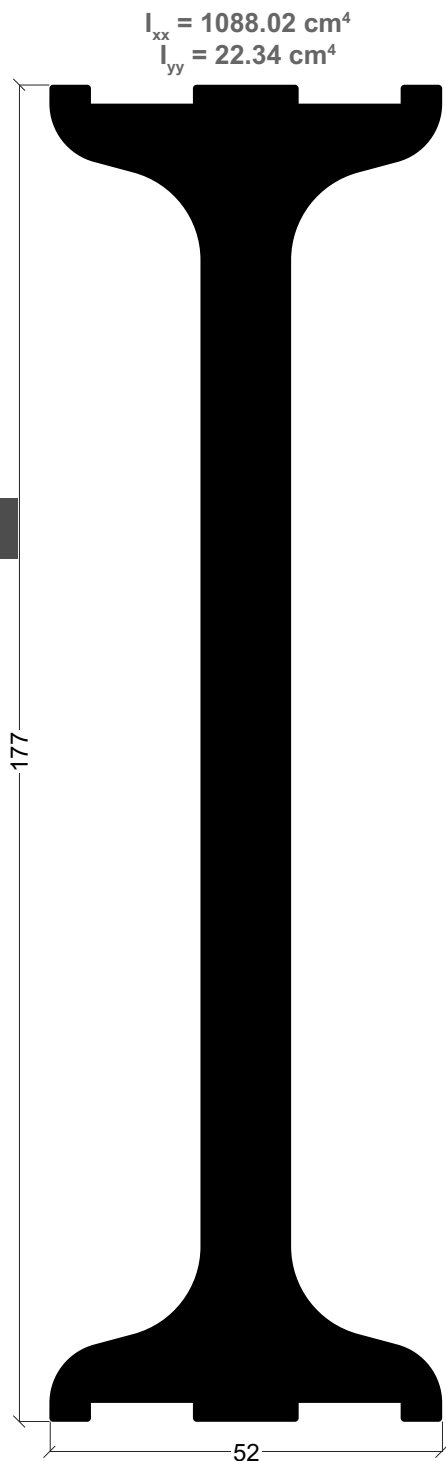

**FL-40**  
IPN de reforço



**FL-21**  
Remate

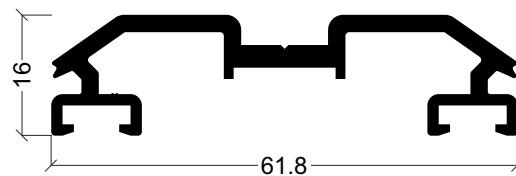

**FL-07**  
Contra tampa

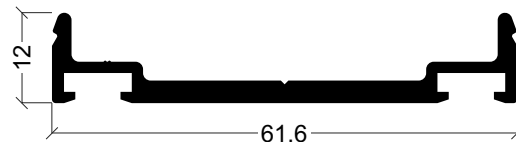

**FL-35**  
Contra tampa



**FL-08**  
Tampa vertical

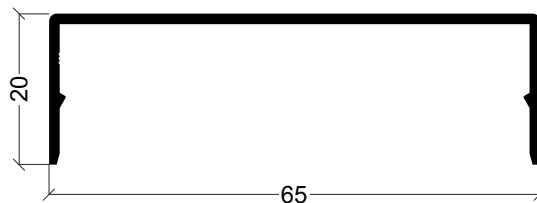

**FL-09**  
Tampa vertical



**FL-33**  
Tampa vertical

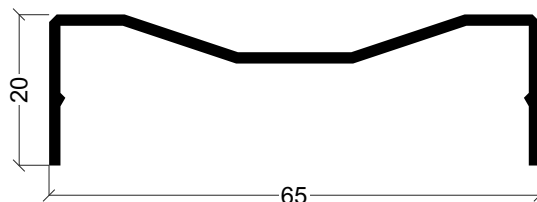

**FL-36**  
Tampa trapezoidal vertical

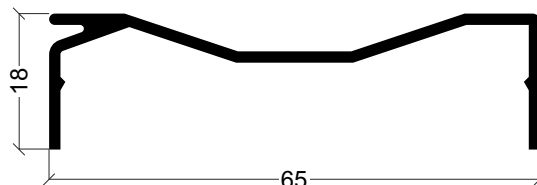

**FL-37**  
Tampa trapezoidal horizontal

**FL-05**

Montante 60 mm regulável

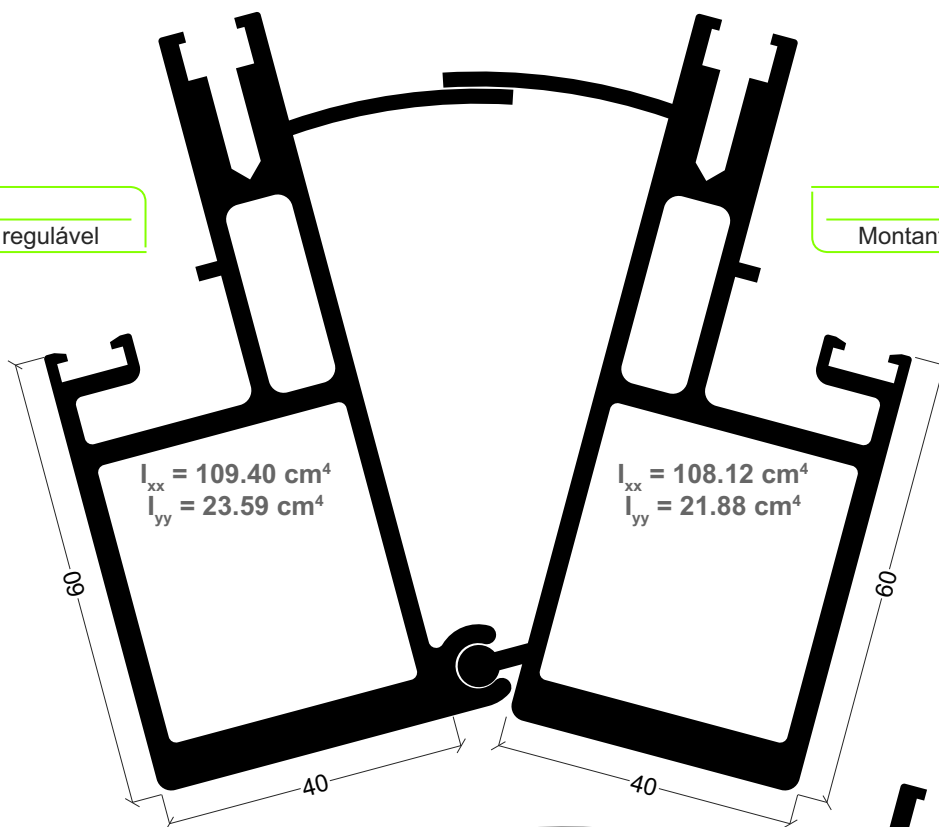

**FL-04**

Montante 60 mm regulável

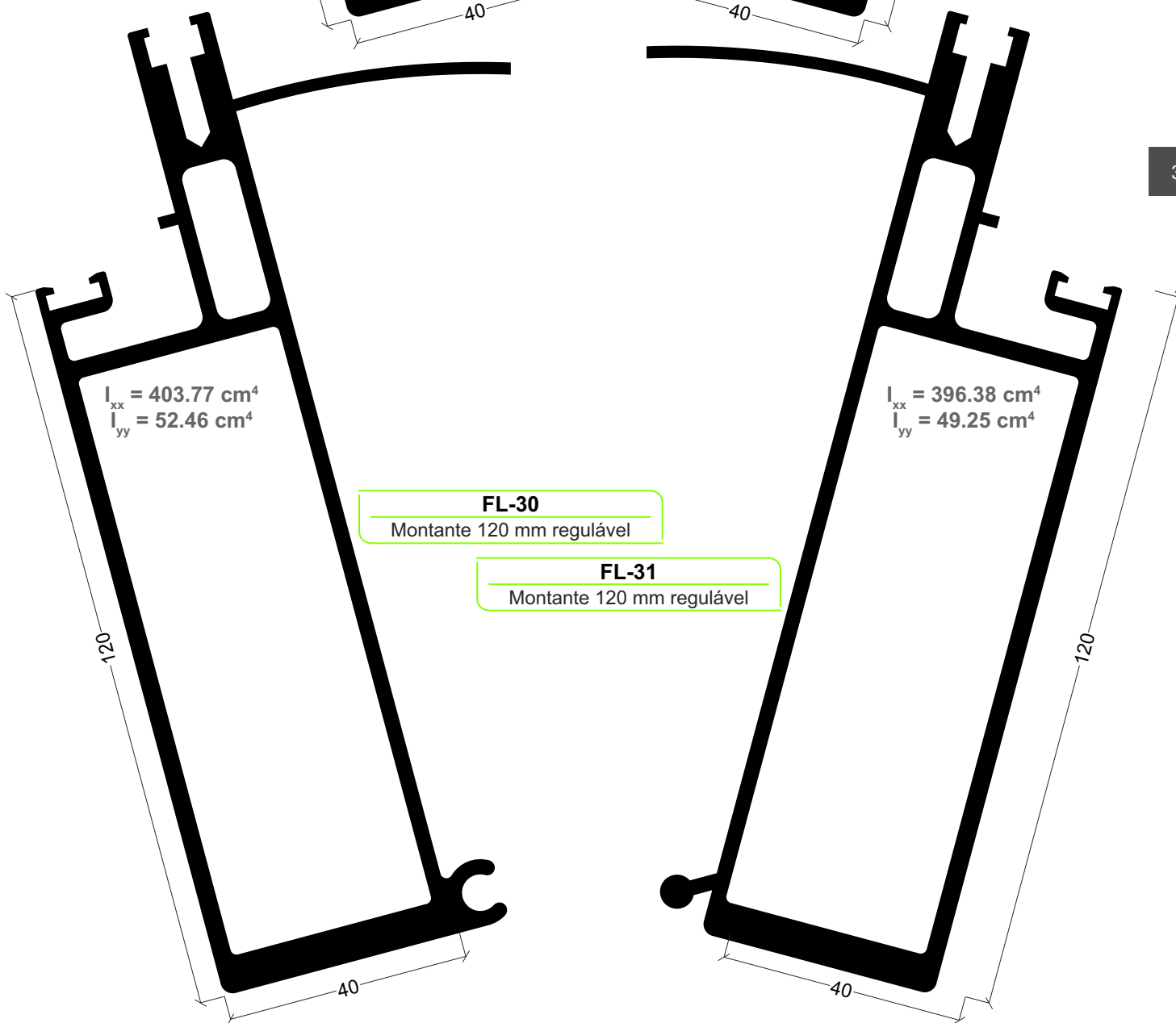

**FL-30**

Montante 120 mm regulável

**FL-31**

Montante 120 mm regulável

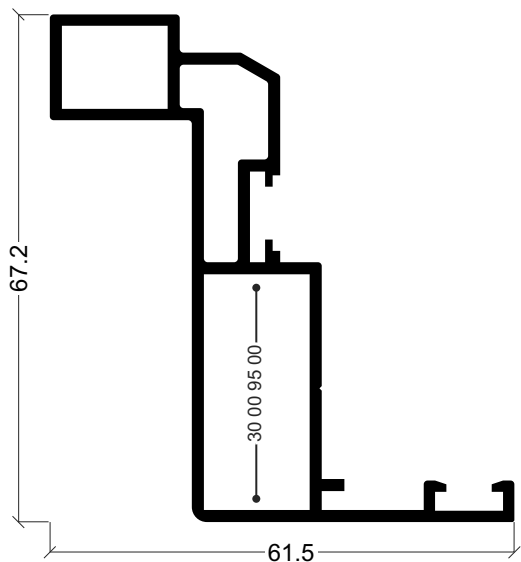

**FL-25**  
Aro fixo projectante

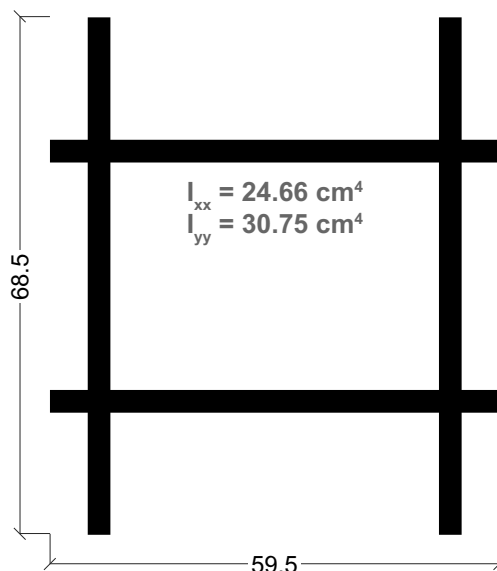

**FL-38**  
União de montantes

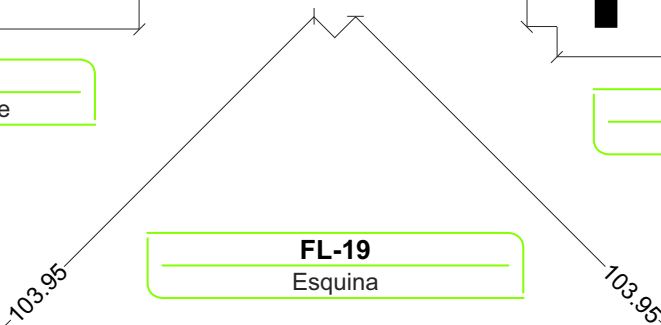

**FL-19**  
Esquina

378

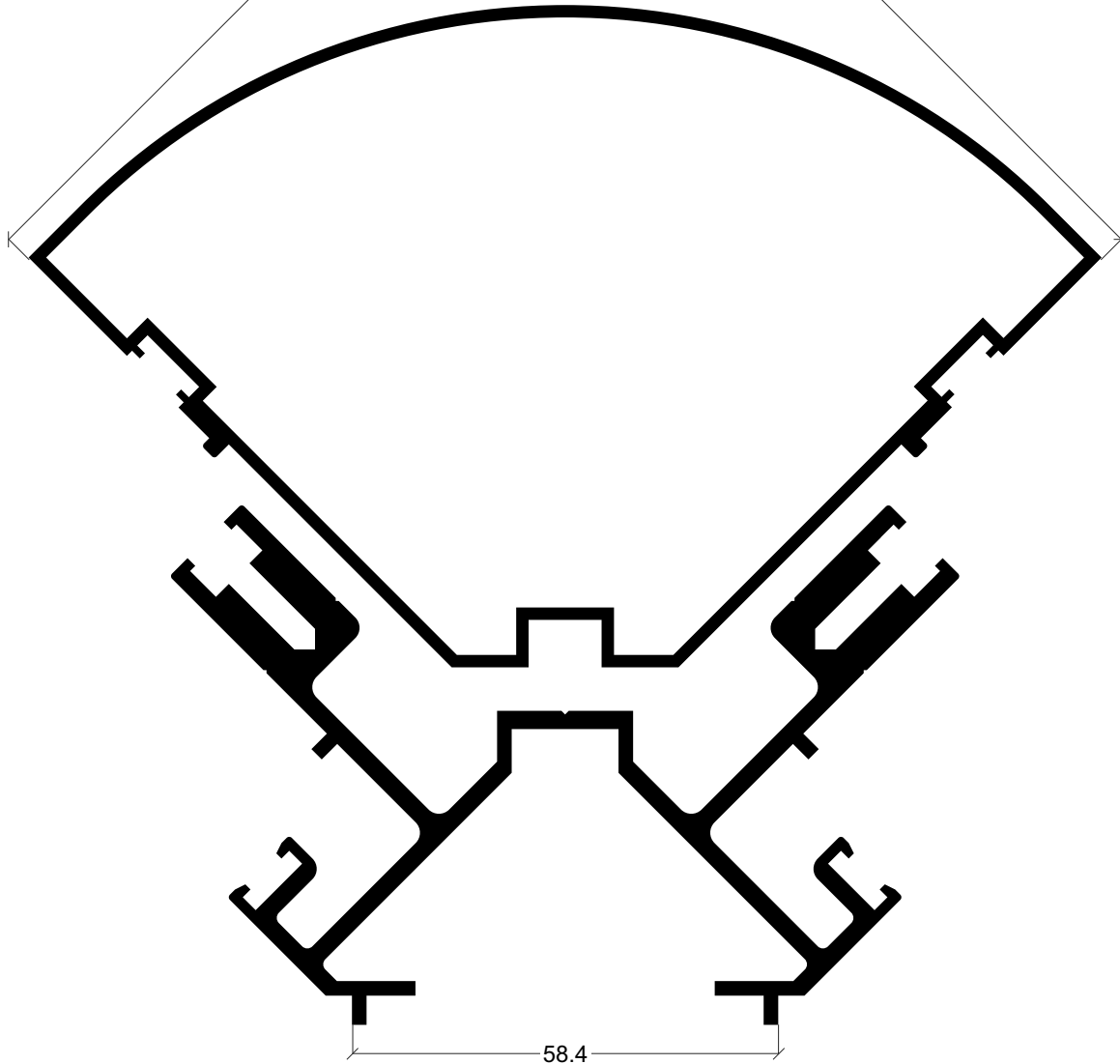

**FL-18**  
Fixador de esquina



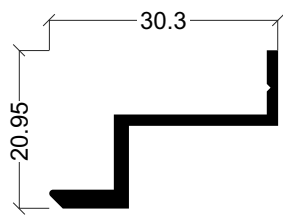

**FL-39**

Perfil de segurança

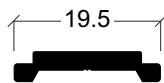

**AX-19**

Vareta

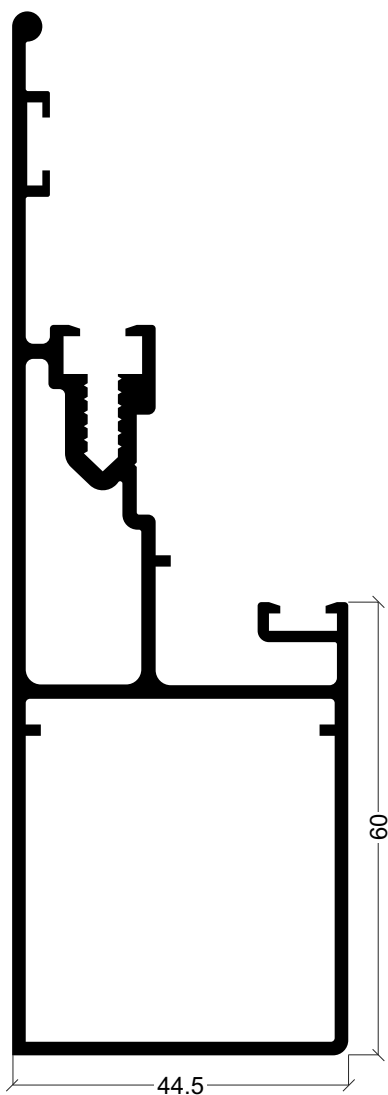

**FL-17**

Montante remate 60 mm

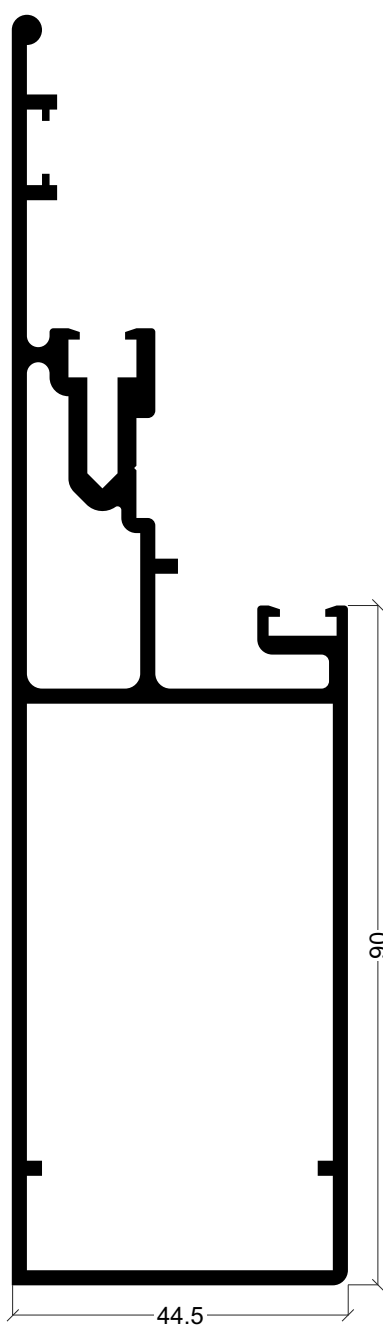

**FL-77**

Montante remate 90 mm

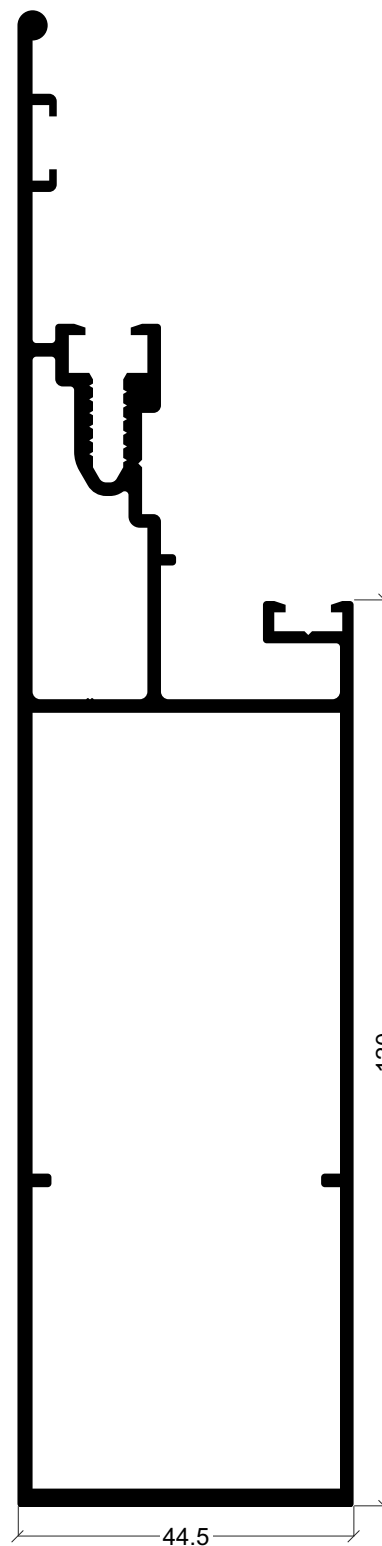

**FL-16**

Montante remate 120 mm

380

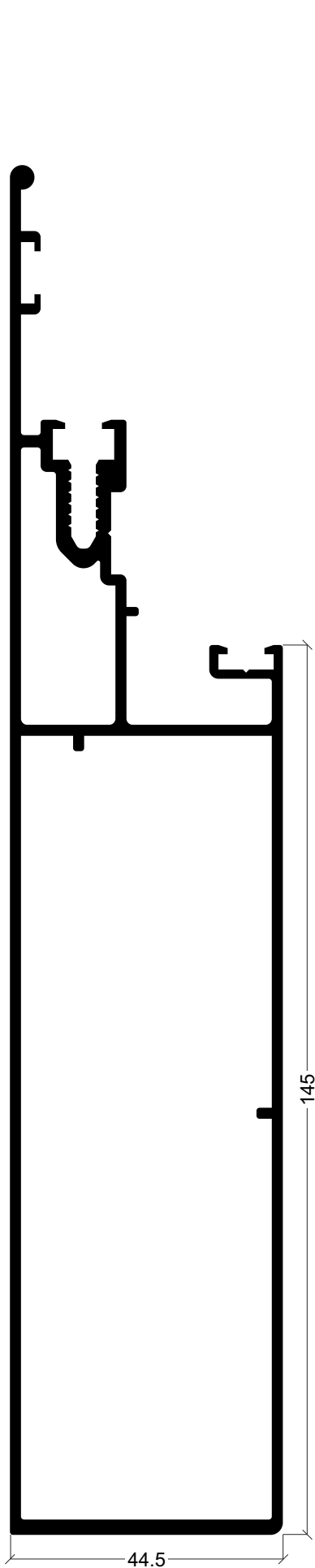

**FL-15**

Montante remate 140 mm

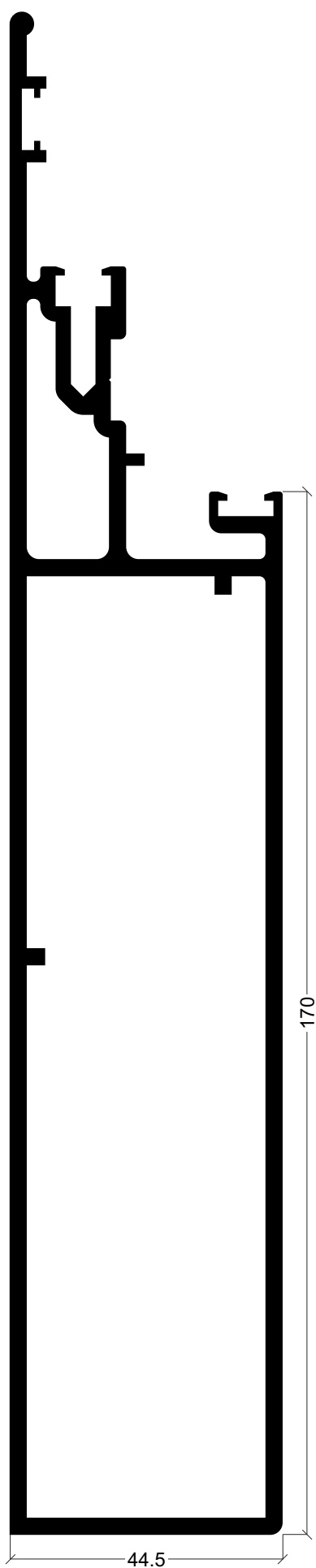

**FL-79**

Montante remate 170 mm

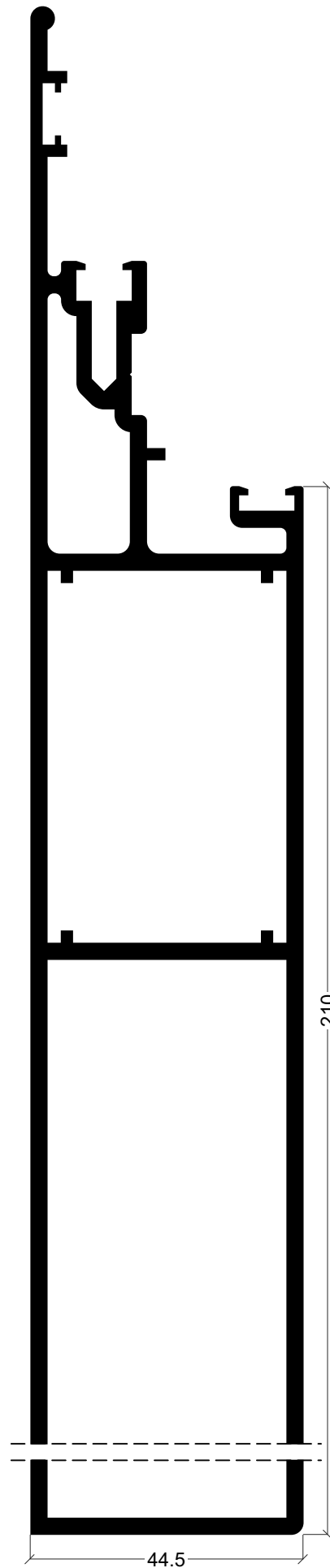

**FL-78**

Montante remate 210 mm

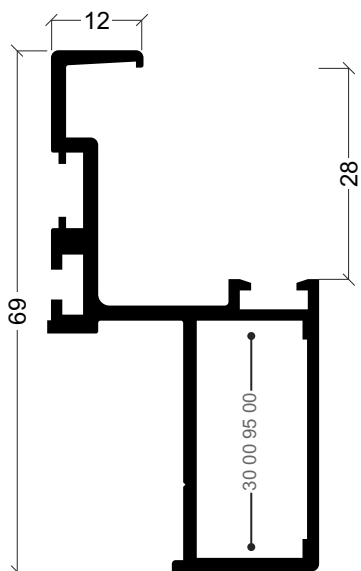

**FL-03**  
Folha semi-estrutural

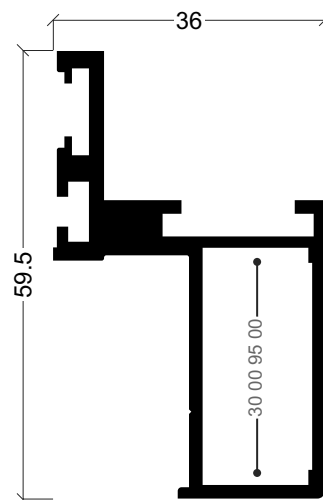

**FL-06**  
Folha estrutural

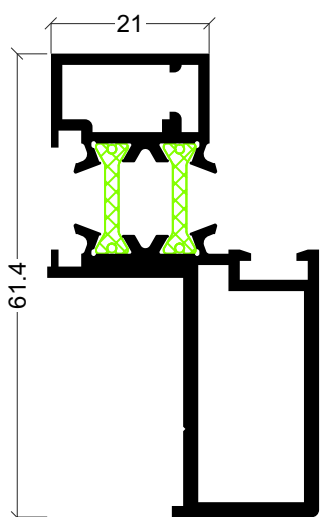

**FL-27**  
Folha estrutural

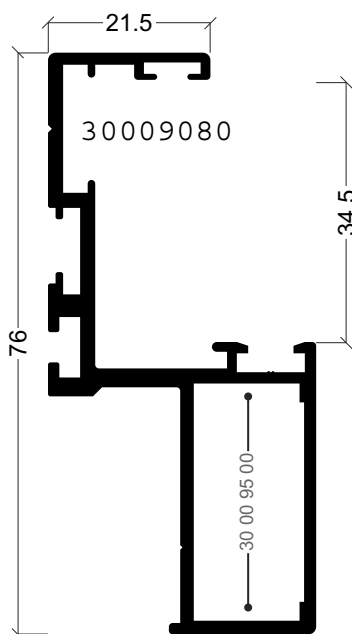

**FL-85**  
Folha semi-estrutural

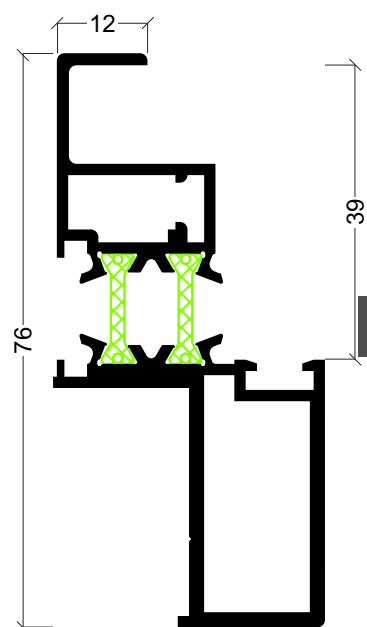

**FL-28**  
Folha semi-estrutural

381

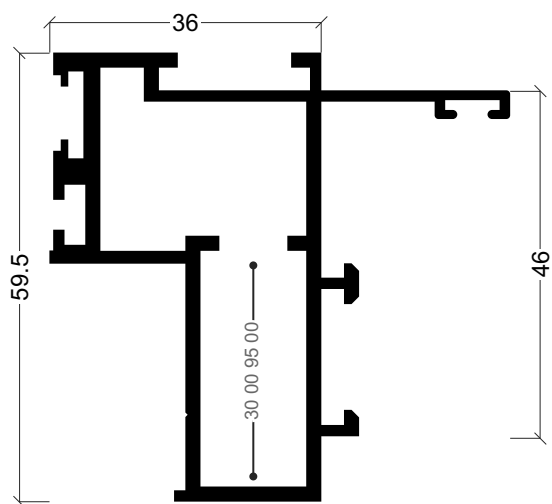

**FL-26**  
Folha estrutural

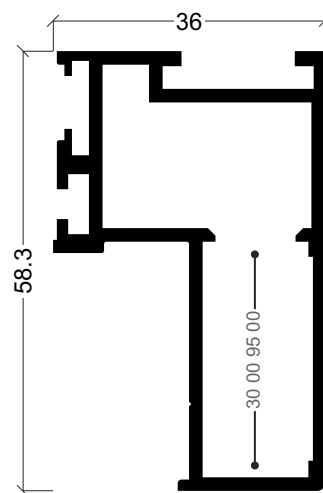

**FL-71**  
Folha estrutural

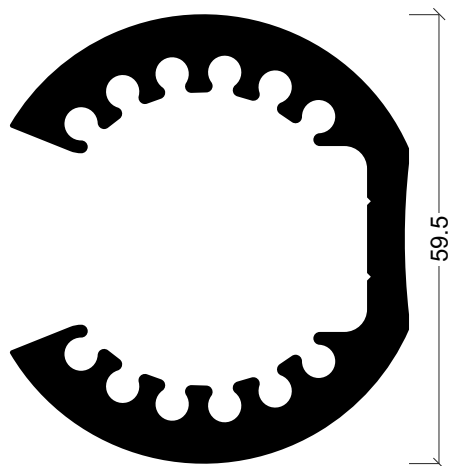

**FL-69**  
Topo de fixação

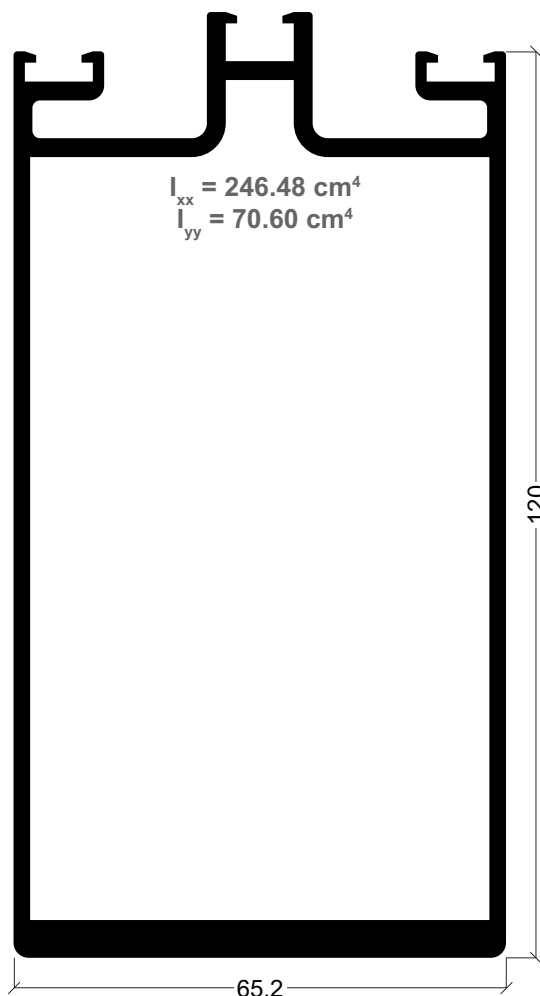

**FL-74**  
Montante 120 mm

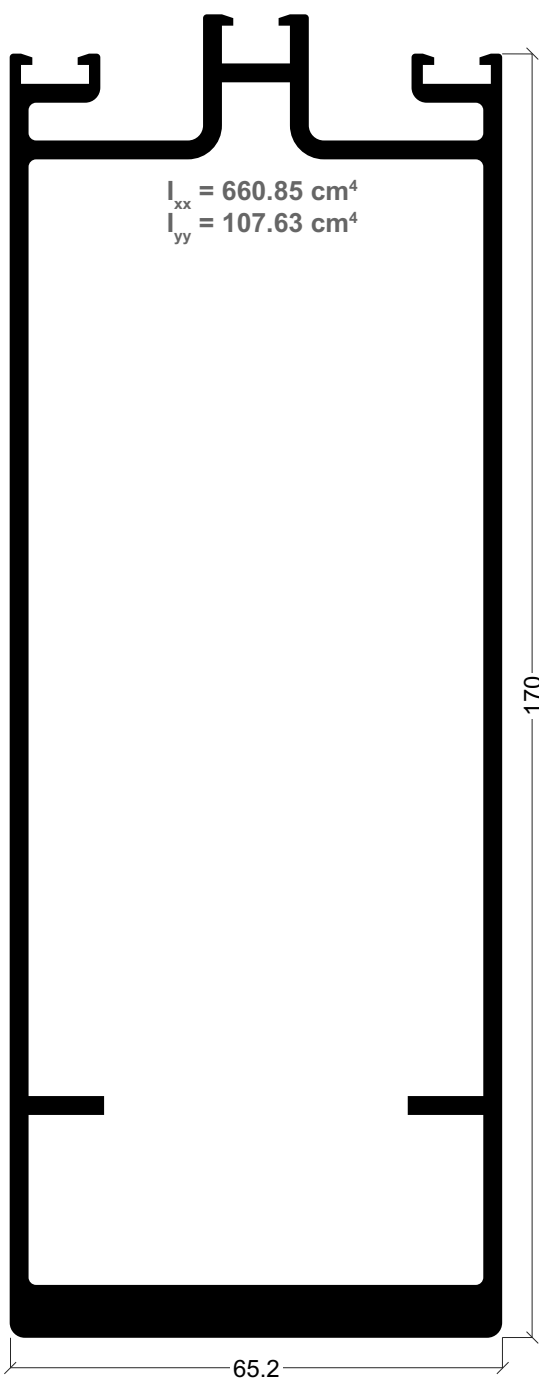

**FL-75**  
Montante 170 mm

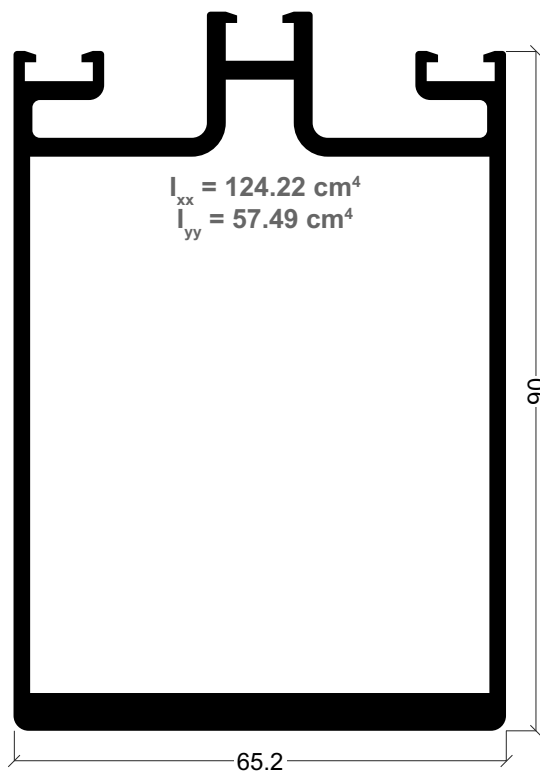

**FL-81**  
Montante 90 mm

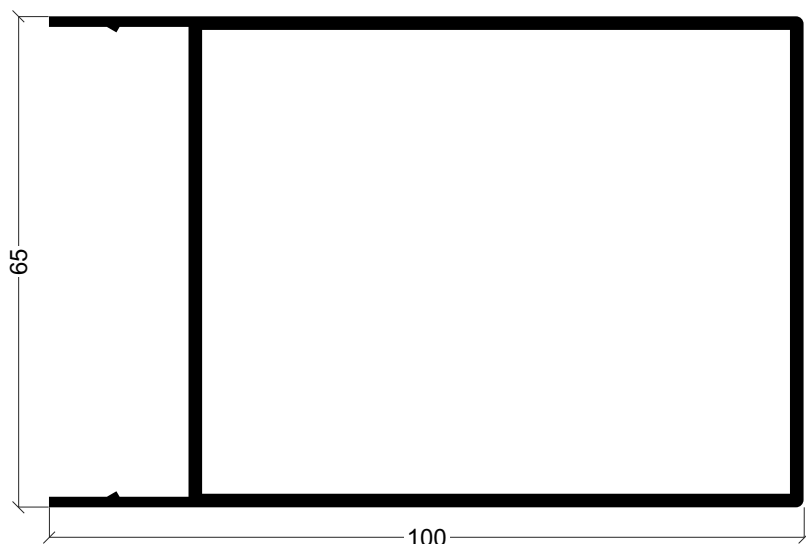

**FL-29**  
Tampa vertical

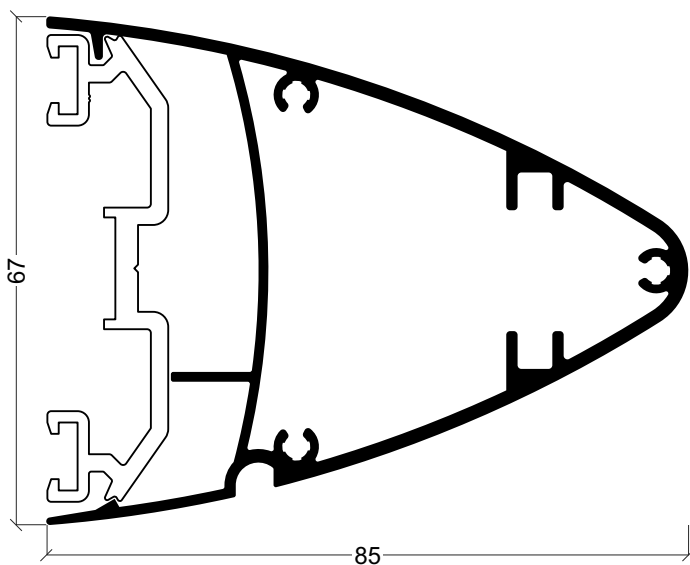

**FL-72**  
Tampa elíptica 85

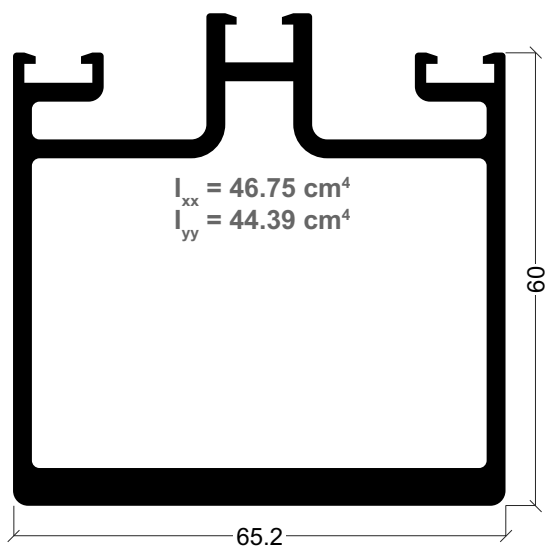

**FL-73**  
Montante 60 mm

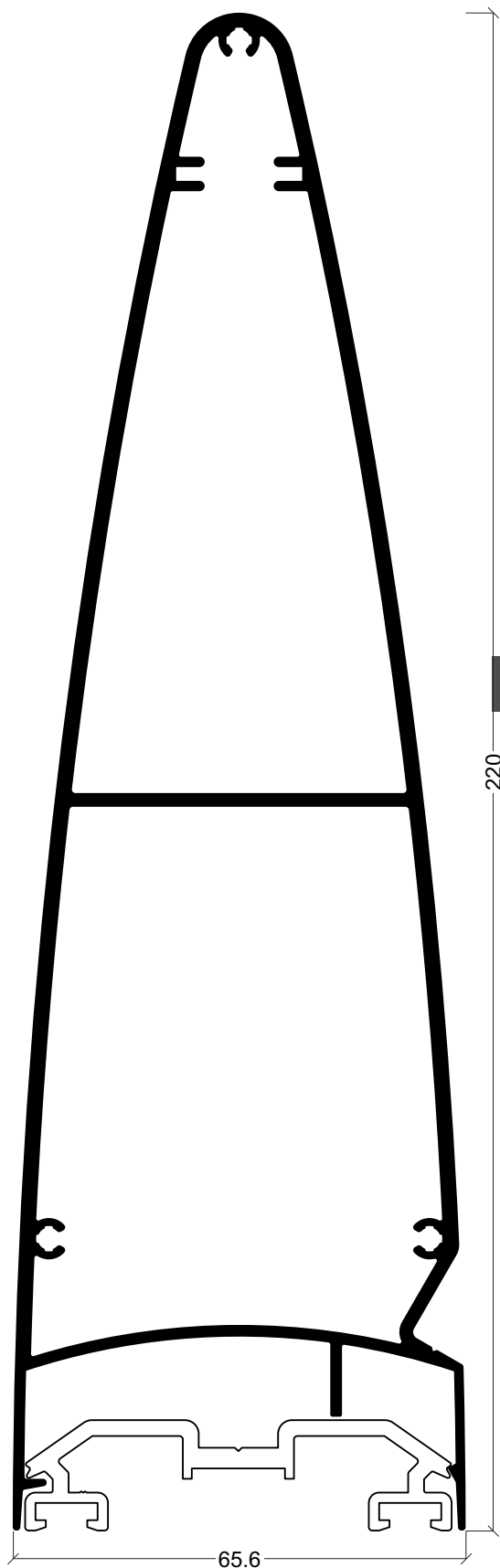

**FL-82**  
Tampa elíptica 220 mm

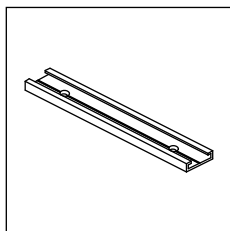

**30 00 90 61**

Guia fixação lateral

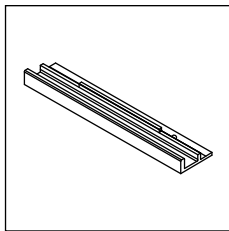

**30 00 90 62**

Fixação lateral montante

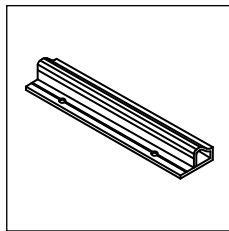

**30 00 90 63**

Fixação inferior

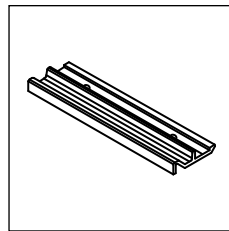

**30 00 90 64**

Fixação inferior travessa

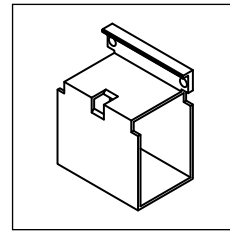

**30 00 90 66**

Topo travessas /  
montante travessa

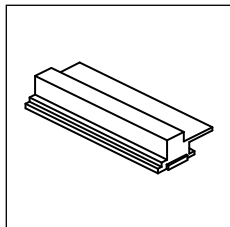

**30 00 90 67**

Fixação lateral folha

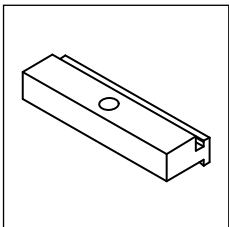

**30 00 90 70**

Fixação frontal

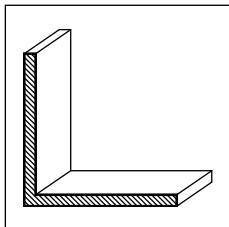

**30 00 90 80**

Canto de reforço

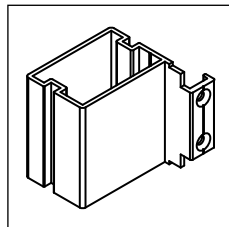

**30 00 94 98**

União fachada montante /  
montante com parafusos

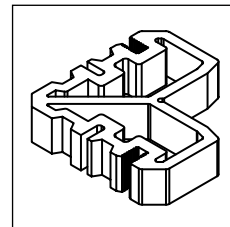

**30 00 94 99**

Esquadro de  
canto 13.7 x 31.6 mm

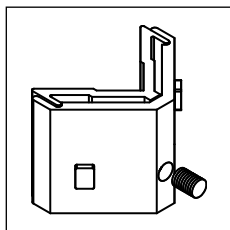

**30 00 95 00**

Esquadro móvel

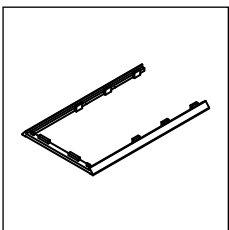

**30 00 95 16**

Junta de estanquidade  
união montantes

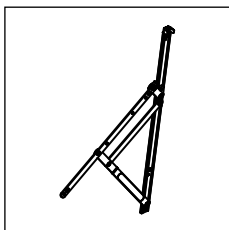

**30 00 95 20**

Jogo compasso fachada  
(120 kg)

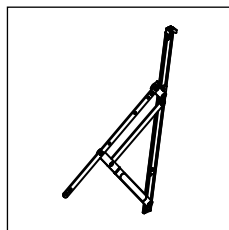

**30 00 95 21**

Jogo compasso fachada  
(180 kg)

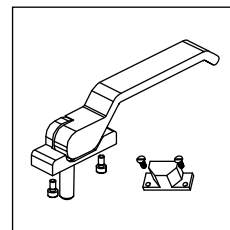

**30 00 95 31/41**

Kit cremone direito/  
esquerdo preto

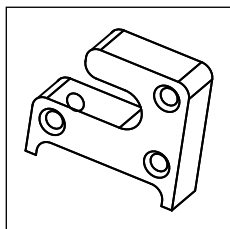

**30 00 95 70**

Peça fixação da folha

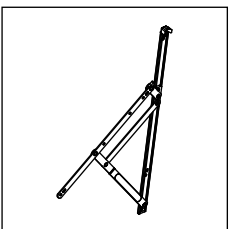

**30 00 95 71**

Jogo compasso fachada  
(60 kg)

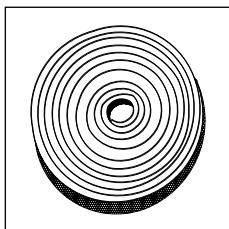

**30 00 95 72**

Junta isolante

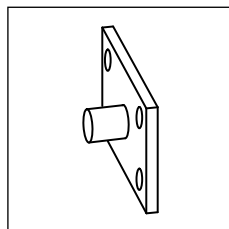

**30 20 90 01**

Fixação lateral folha

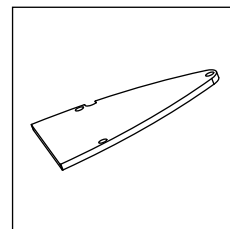

**30 23 90 97**

Tampa elíptica 85 mm

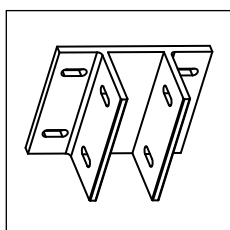

**31 00 90 65**

Fixador montante

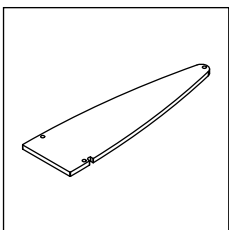





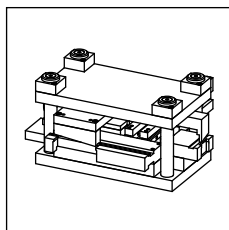









**33 00 95 73**

Tampa elíptica 220 mm



**33 97 79 99**

Cunho FL

Referência	Desenho	Descrição
30 00 95 01		Junta interior montante Junta central montante e travessa (muro invertido)
30 00 95 02		Junta interior montante (fxação lateral folhas fixas)
30 00 95 03		Junta central (montante e travessa) Fachada estrutural e semi-estrutural
30 00 95 05		Junta interior de travessa Junta de aro fixo (janela oculta em muro invertido)
30 00 95 06		Junta central montante e travessa
30 00 95 07		Junta central montante e travessa
30 00 95 08		Junta central montante e travessa (segundo vidro)
30 00 95 09		Junta de estanquidade montante FL-11
30 00 95 10		Junta de estanquidade travessa FL-12
30 00 95 13		Junta folha de rotura térmica
30 00 95 76		Junta central montante e travessa
30 20 26 03		Junta exterior Junta interior Junta de vedação
30 90 20 80		Junta exterior para Sistema Ergolux
30 99 95 11		Junta de folha encaixe exterior Junta montante de remate Junta de folha e aro (janela oculta em muro invertido)

### Pormenor de fixação do montante

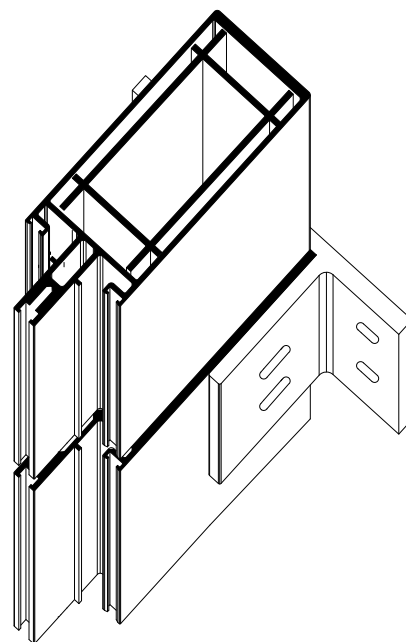
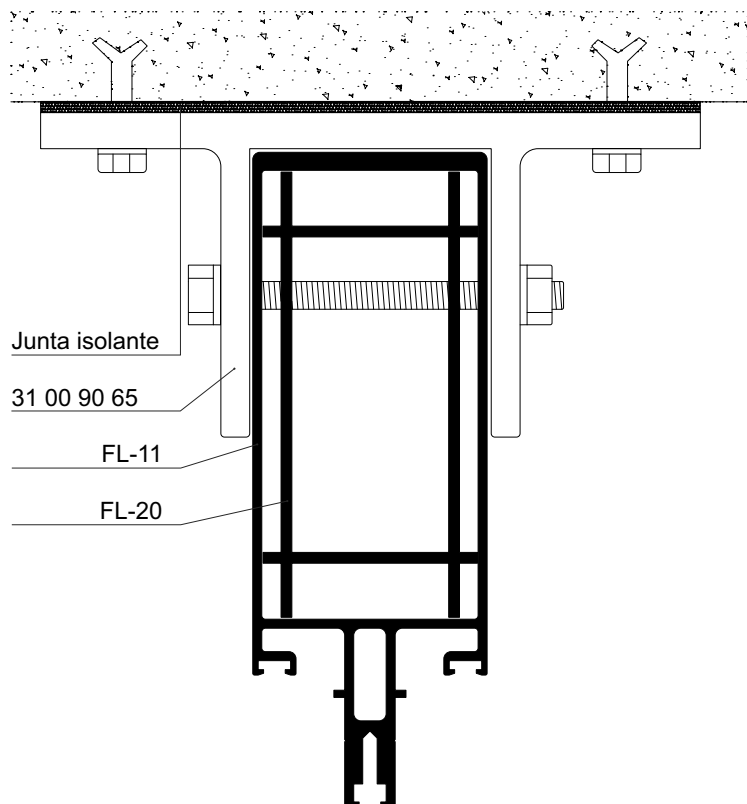

386

### União montante travessa

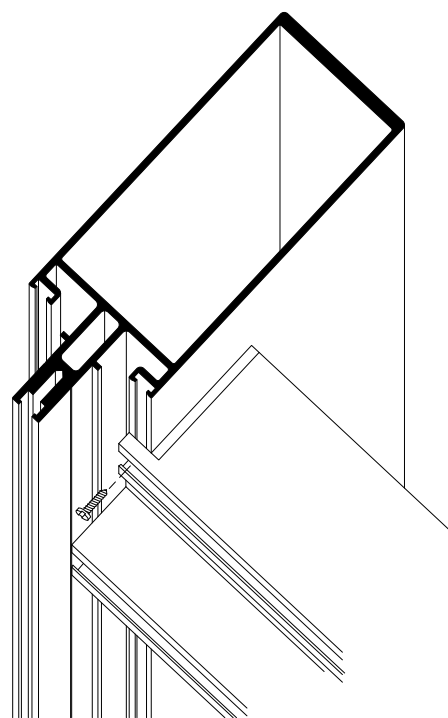
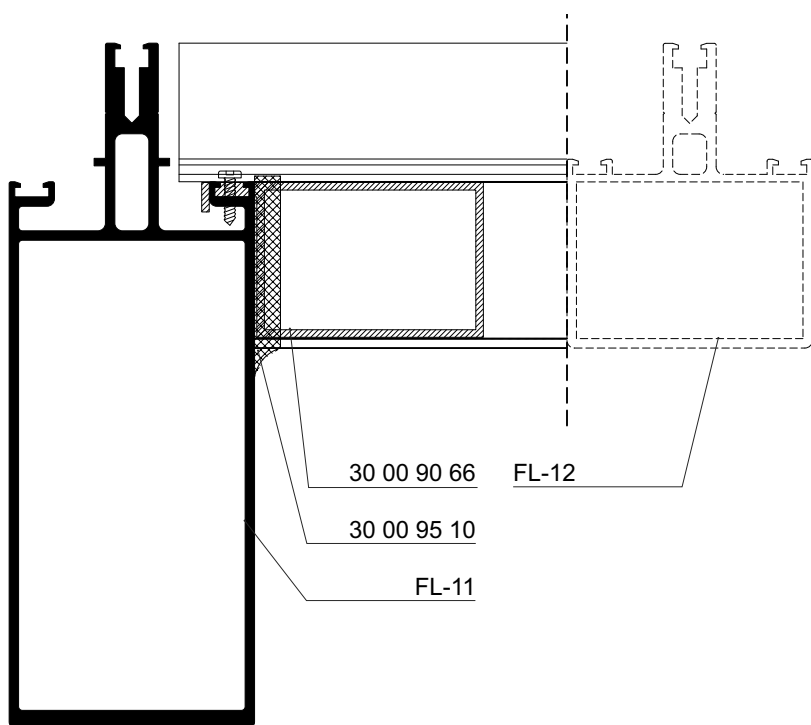



### Folha de corte da travessa

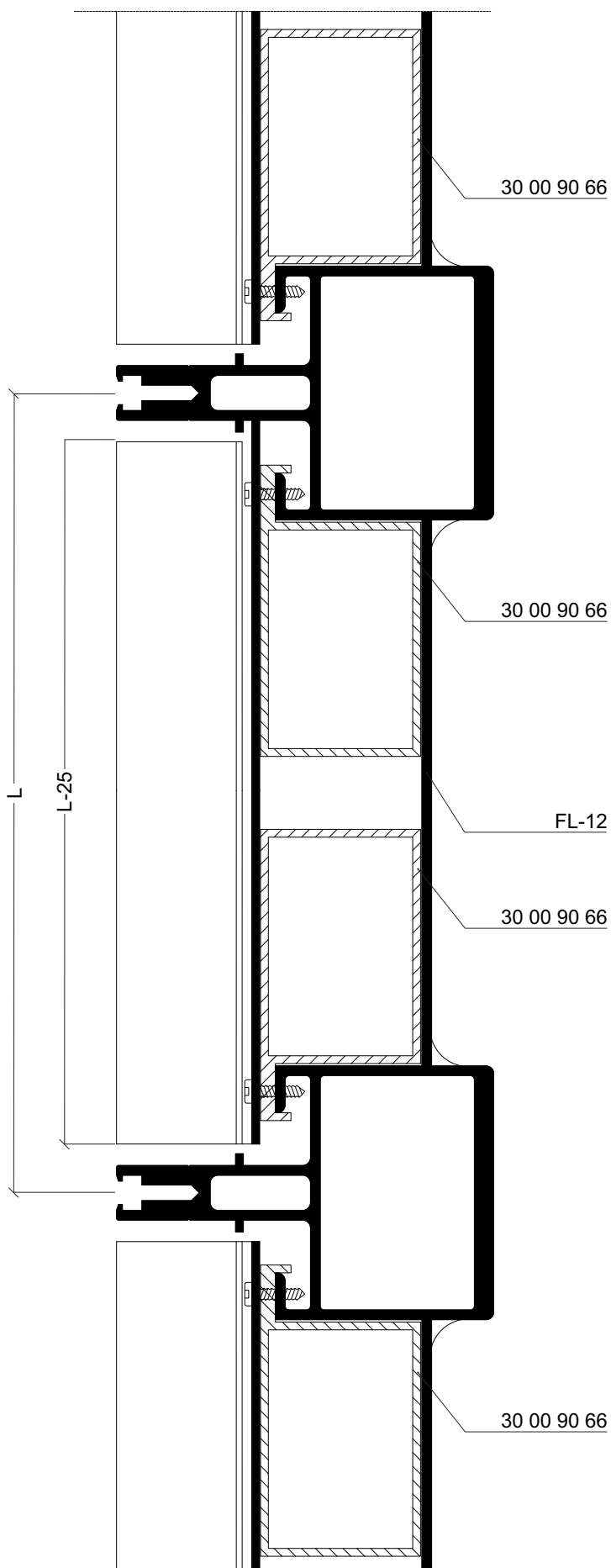

Medidas de corte fachada estrutural e semi-estrutural

Pormenor horizontal e vertical sistema de fixação frontal

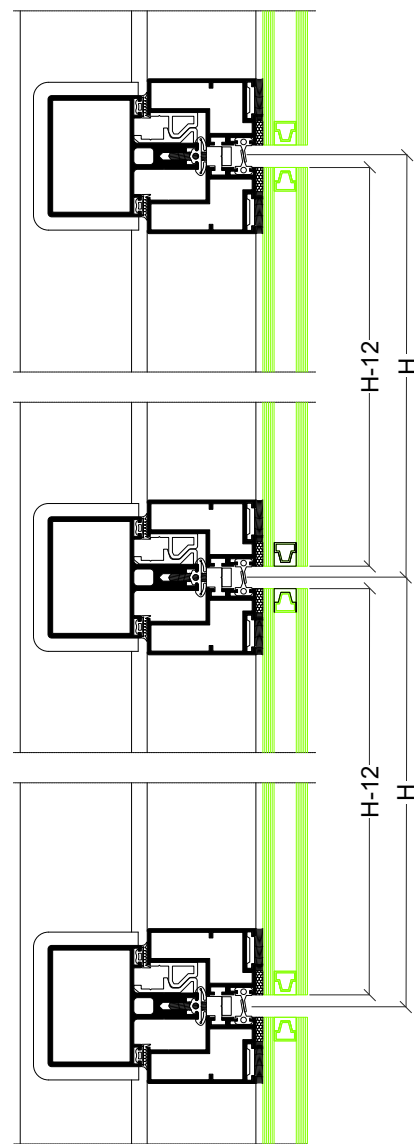
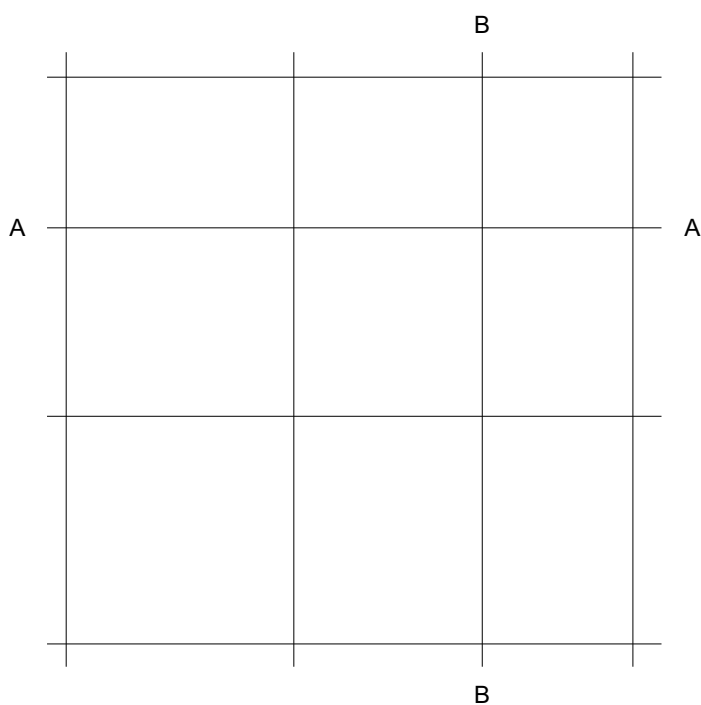

Seção A-A

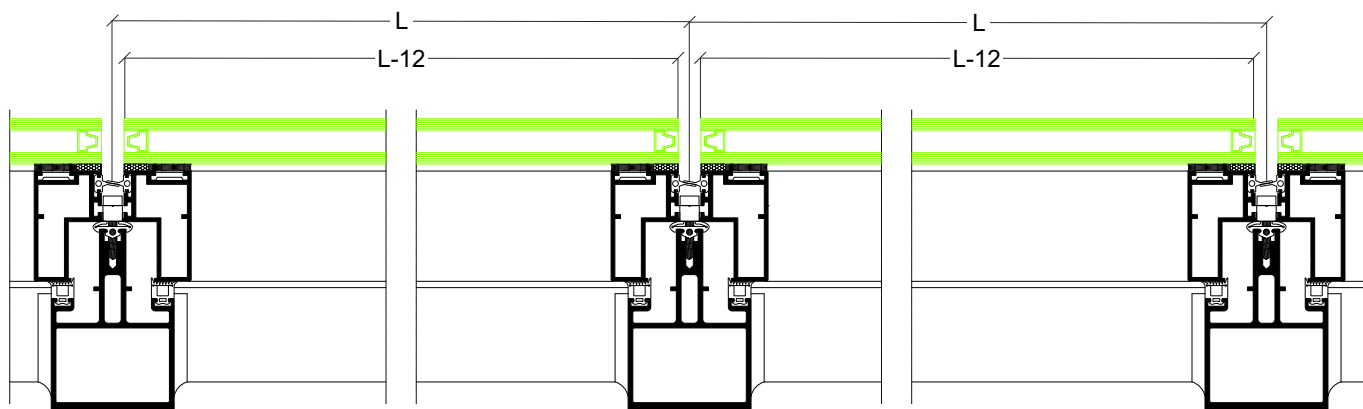

Seção B-B

### Montagem da folha fixa

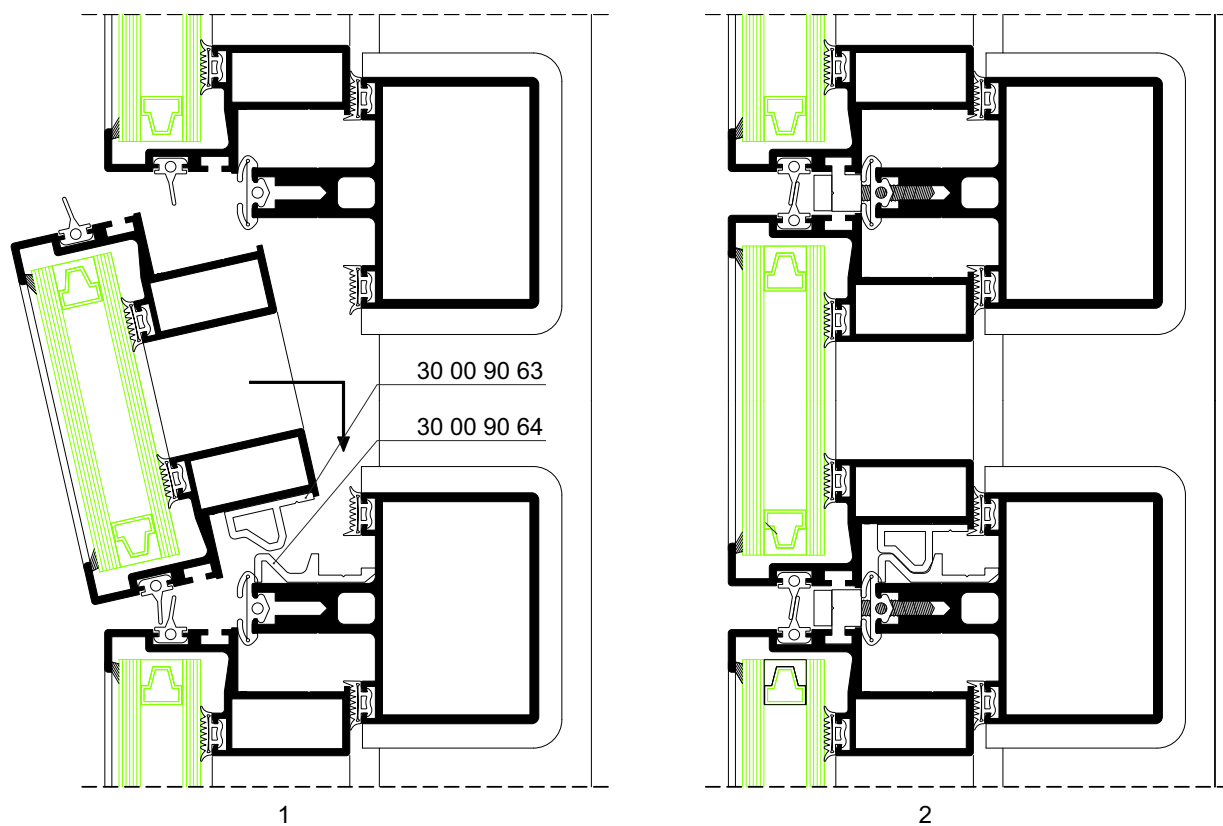

### Montagem da folha fixa

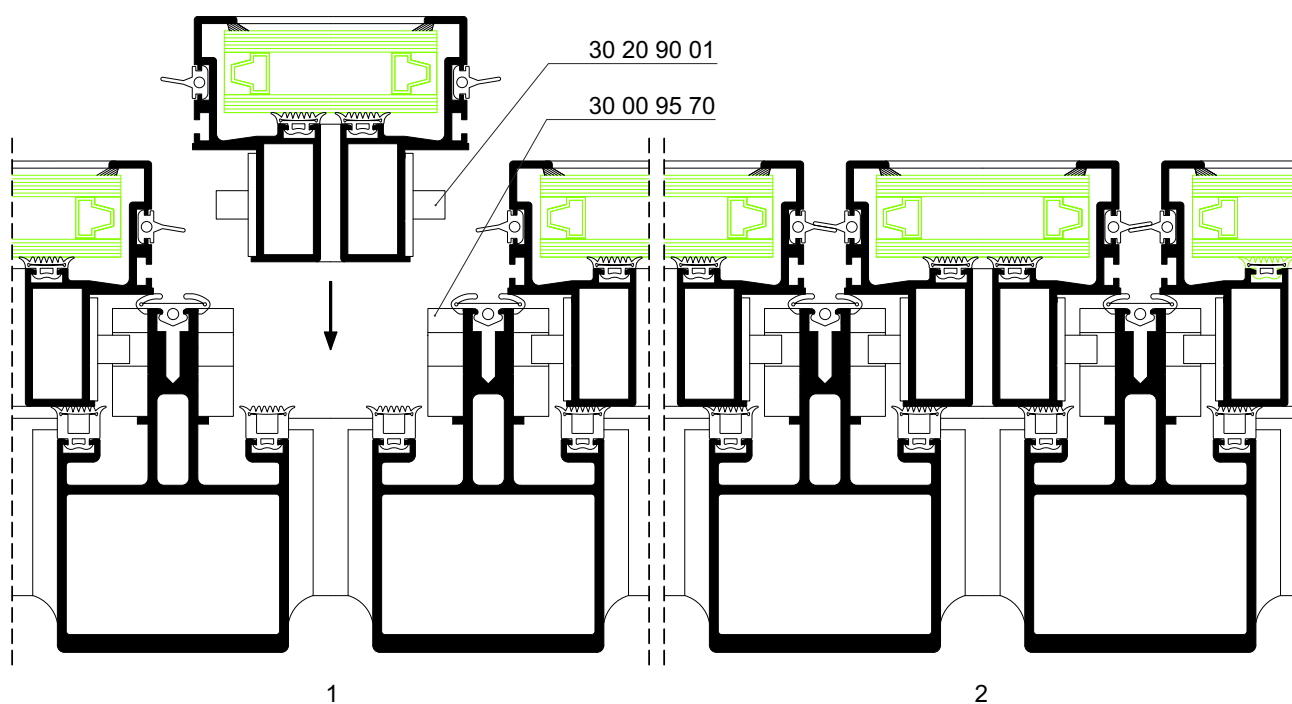

## Fachada estrutural e semi-estrutural Sistema de fixação de folhas fixas

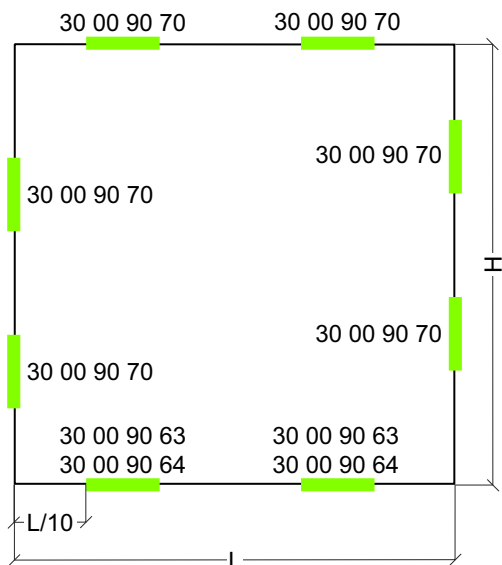

### Folha fixa Sistema de fixação frontal

Peça de fixação	L	H	Nº de peças	
			L	H
30 00 90 70	até 1000 mm	até 1000 mm	2	2
	cada 500 mm	cada 500 mm	1	1

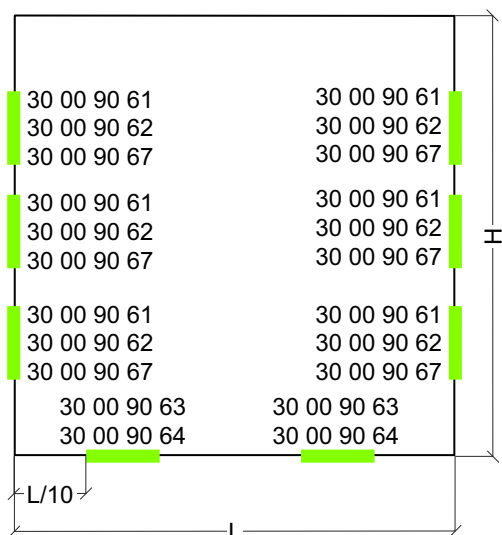

### Folha fixa Sistema de fixação interior lateral

Peça de fixação	L	H	Nº de peças	
			L	H
30 00 90 61 30 00 90 62 30 00 90 67	até 1000 mm	até 1000 mm	-	3
	cada 500 mm	cada 500 mm	-	1
30 00 90 63 30 00 90 64	até 1000 mm	até 1000 mm	2	-
	cada 500 mm	cada 500 mm	1	-

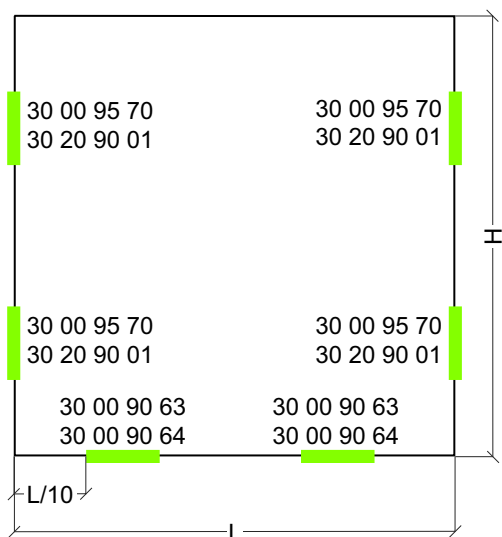

### Folha fixa Sistema de fixação exterior lateral

Peça de fixação	L	H	Nº de peças	
			L	H
30 00 95 70 30 20 90 01	-	-	-	2
	-	-	-	-
30 00 90 63 30 00 90 64	até 1000 mm	até 1000 mm	2	-
	cada 500 mm	cada 500 mm	1	-

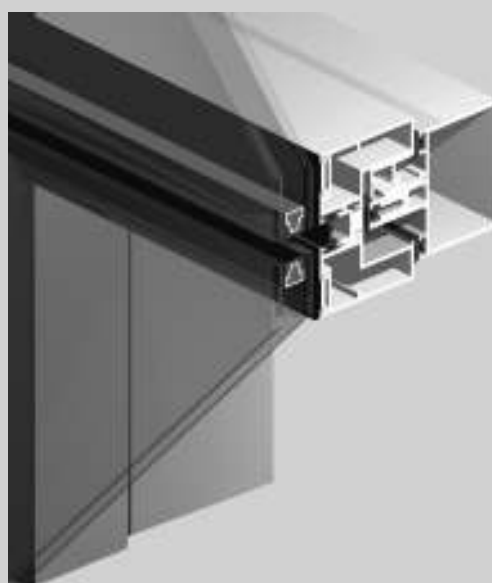
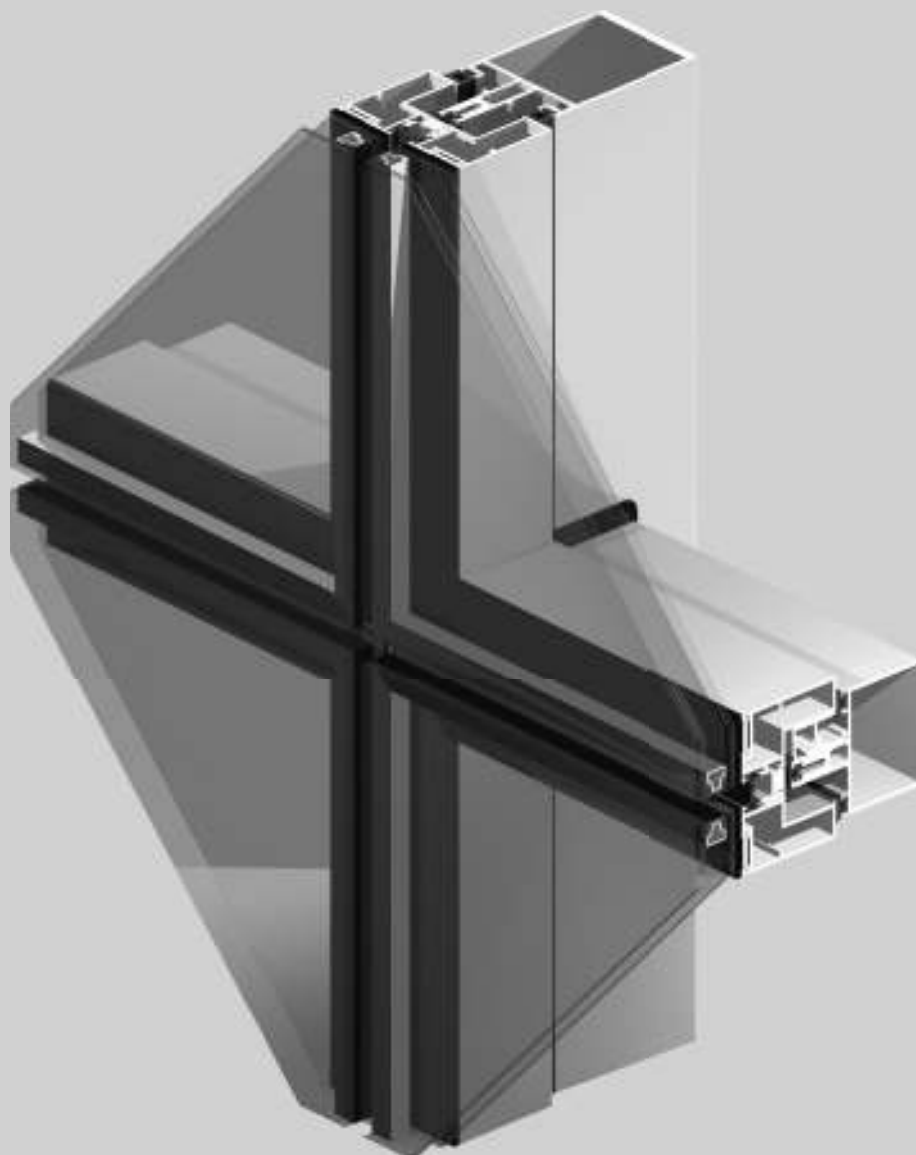

**Fachada Estrutural**

## Fachada Estrutural

### Características

Neste sistema a colocação de vidros realiza-se mediante bastidores nos quais se coloca um perfil especialmente anodizado para permitir a colagem da silicone estrutural. Deste modo, o vidro oculta totalmente os perfis, adquirindo este tipo de fachada, uma vista exterior só de vidro, proporcionando assim um efeito tipo VEC - Vidro Exterior Colado.

A secção dos montantes e travessas é de 65 mm, visível apenas do interior.

Ambos os perfis apresentam canais de drenagem e ventilação que garantem, juntamente com o sistema de juntas de EPDM, uma estanquidade e permeabilidade máximas. Opcionalmente, dispõe-se de um perfil especial de segurança que evita o esforço cortante do vidro. Possibilidade de perfis com rotura térmica.

### Acabamentos

A barra que recebe o vidro tem que possuir uma anodização especial do perfil perimetral ( $>20 \mu\text{m}$ ), necessária para garantir uma perfeita colagem do vidro com silicone estrutural. A restante perfilaria permite todas as possibilidades de acabamento: lacado, lacado decorativo (madeira) ou anodizado.

### Possibilidades de abertura

Abertura projectante realizada por intermédio de compassos em aço inox com uma resistência até 180 kg, Tanto as folhas fixas como as projectantes são fabricadas com o mesmo perfil perimetral, tornando assim imperceptível a sua distinção pelo exterior.

**Pormenor horizontal e vertical**

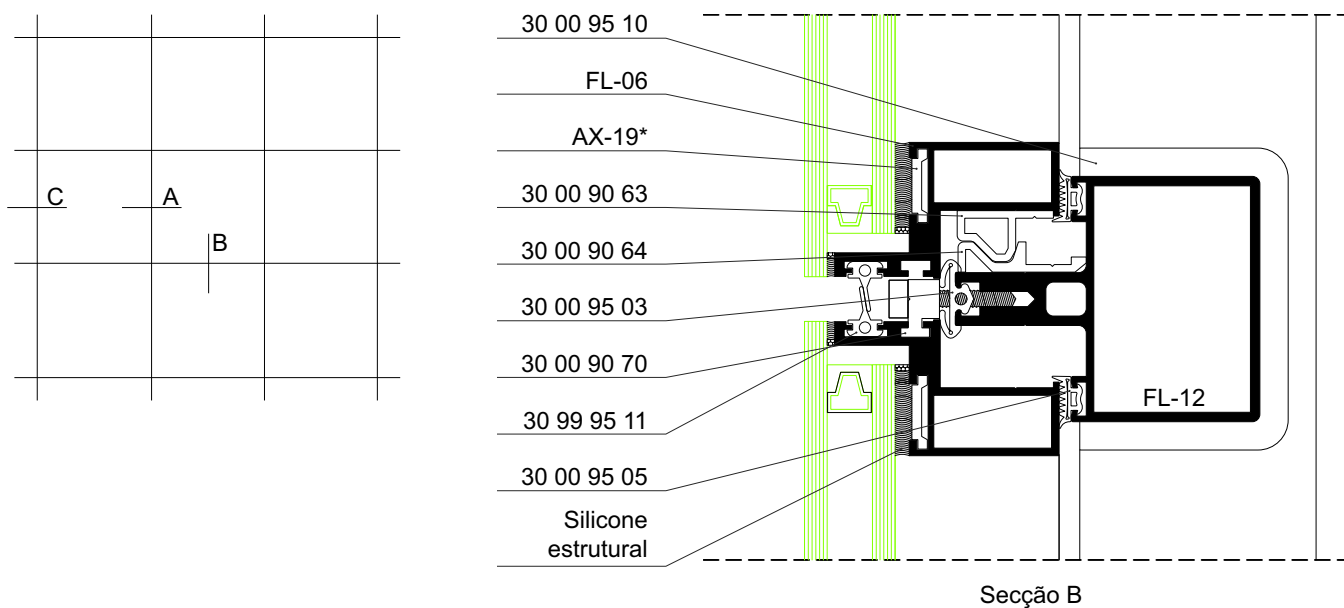

\* Perfil anodizado com classe 20, colagem especial com silicone estrutural

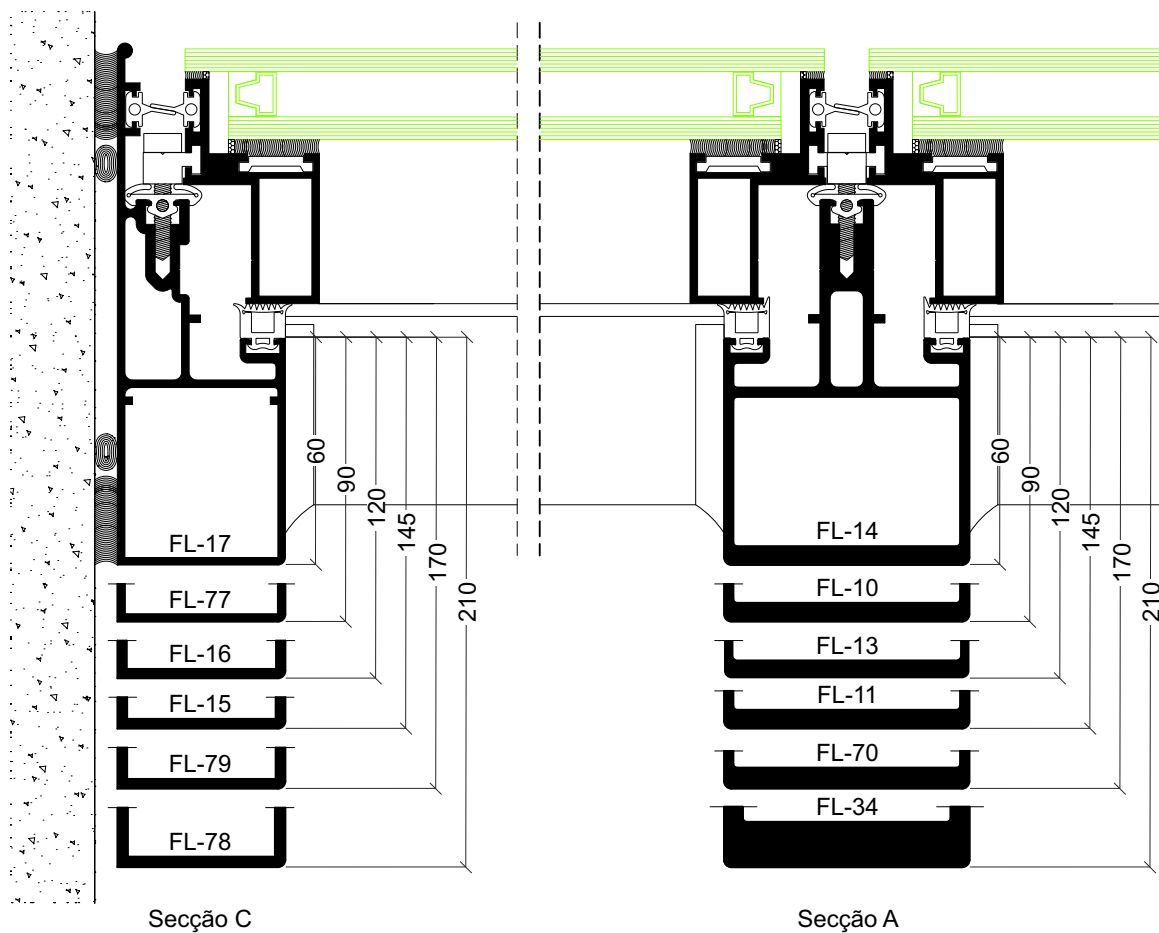

**Pormenor canto 90°**

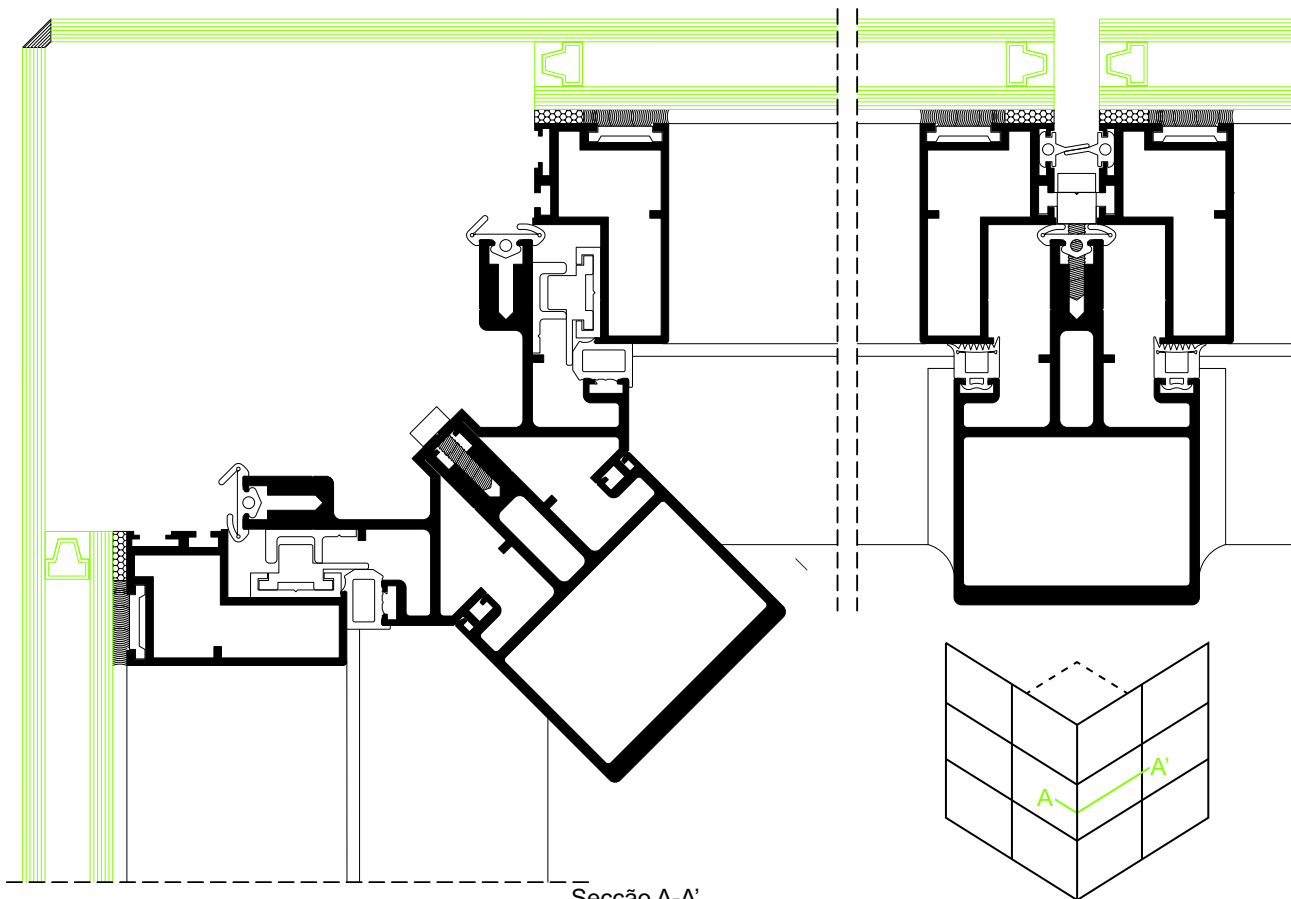

**Pormenor canto 90°**

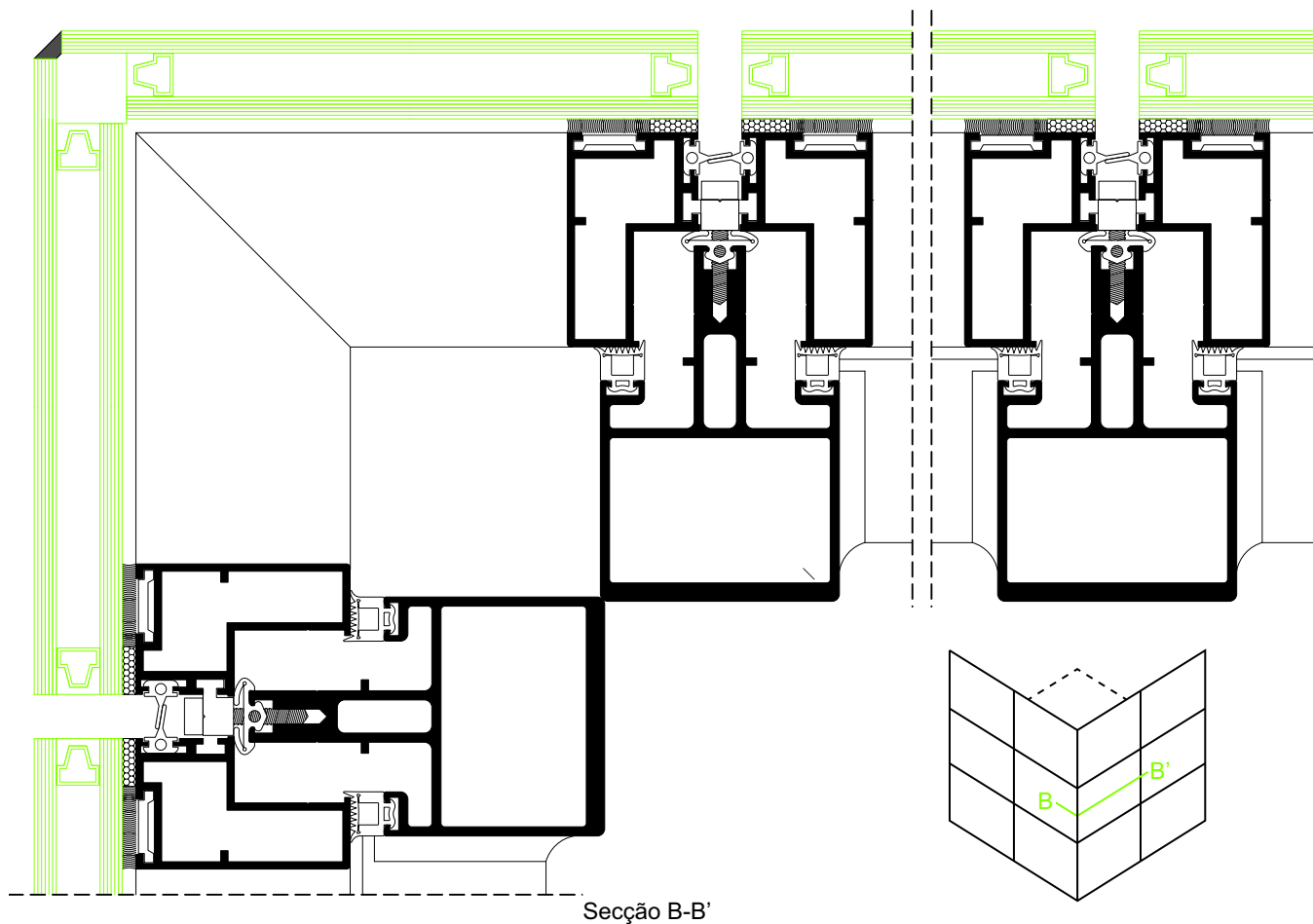



### Pormenor canto 90°

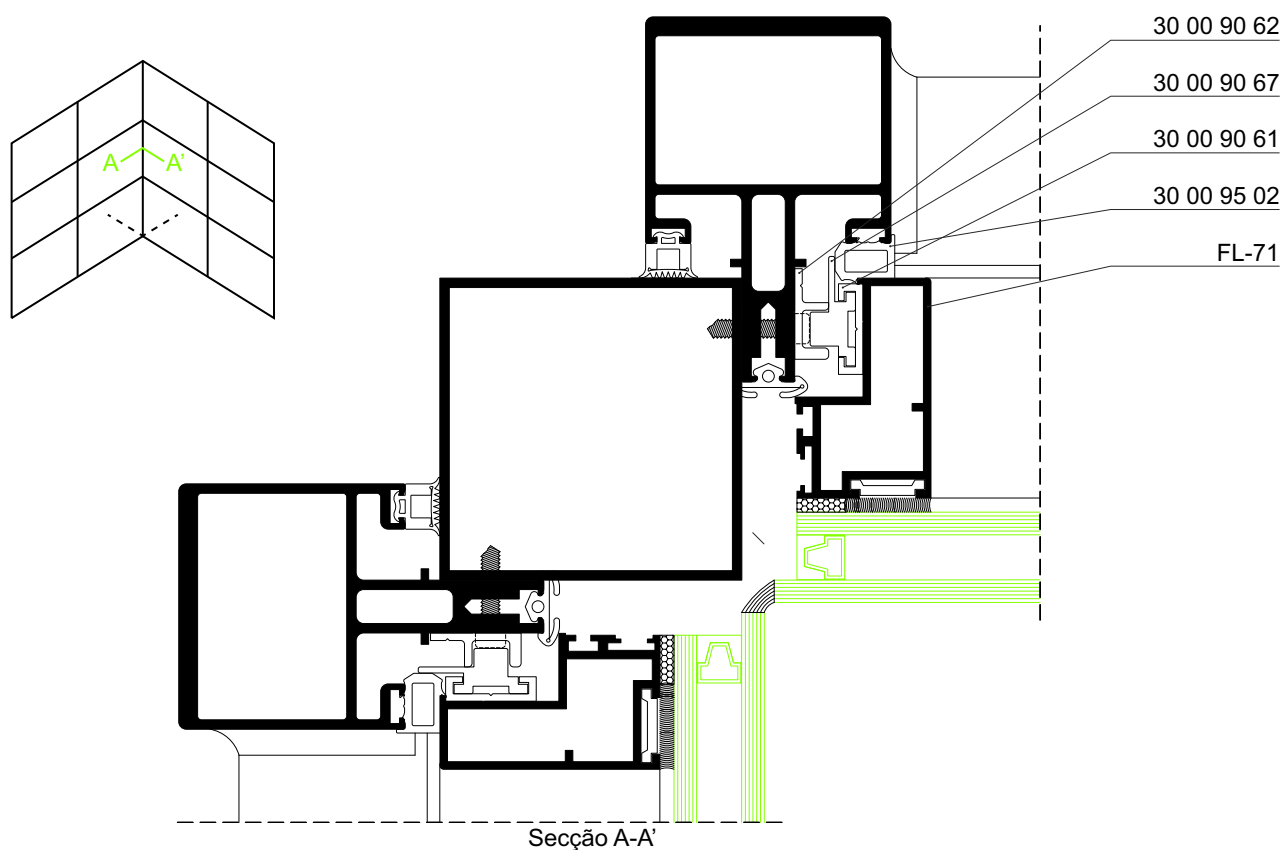

### Pormenor canto variável de 15° a 30°

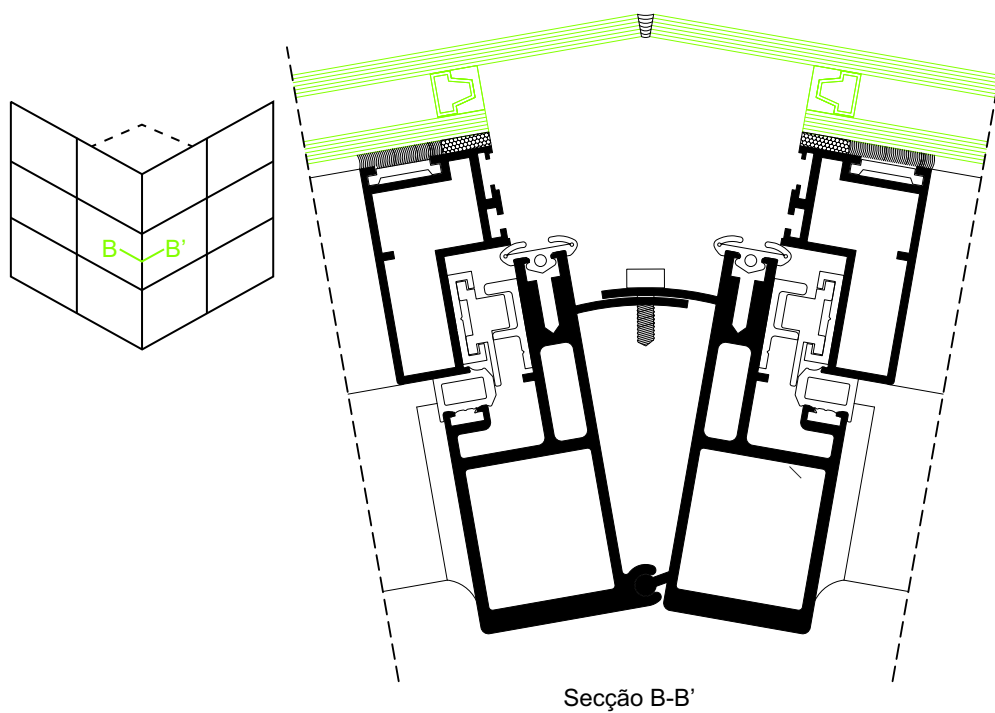

**Pormenor horizontal e vertical**

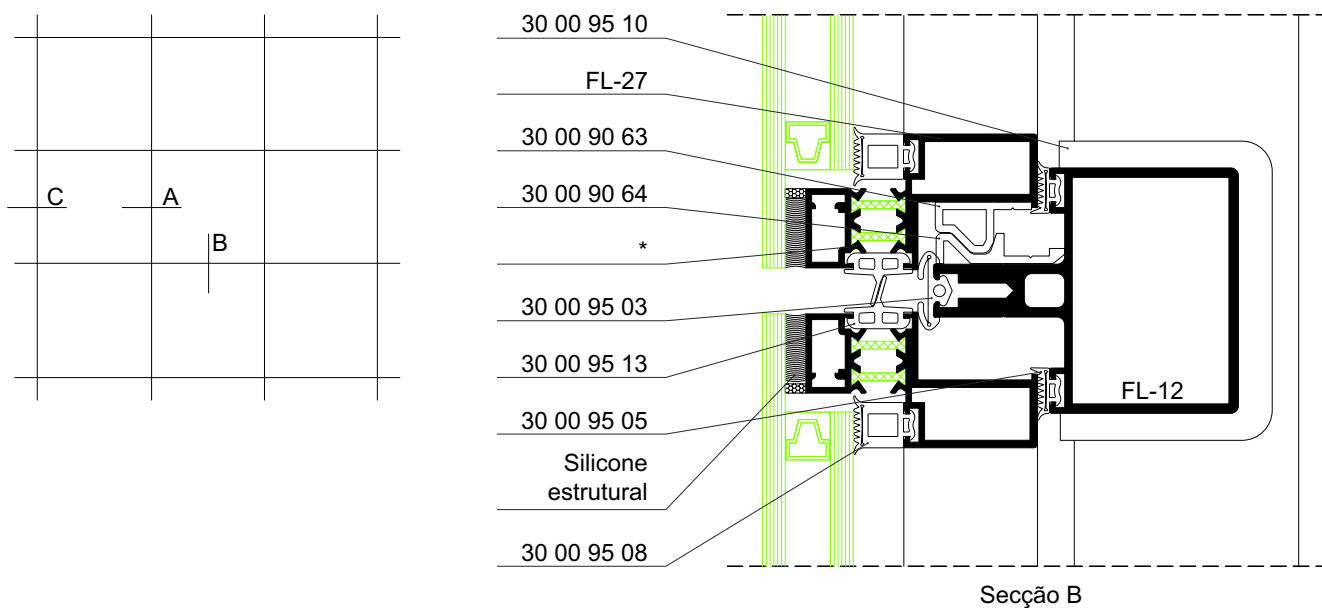

\* Perfil anodizado com classe 20, colagem especial com silicone estrutural

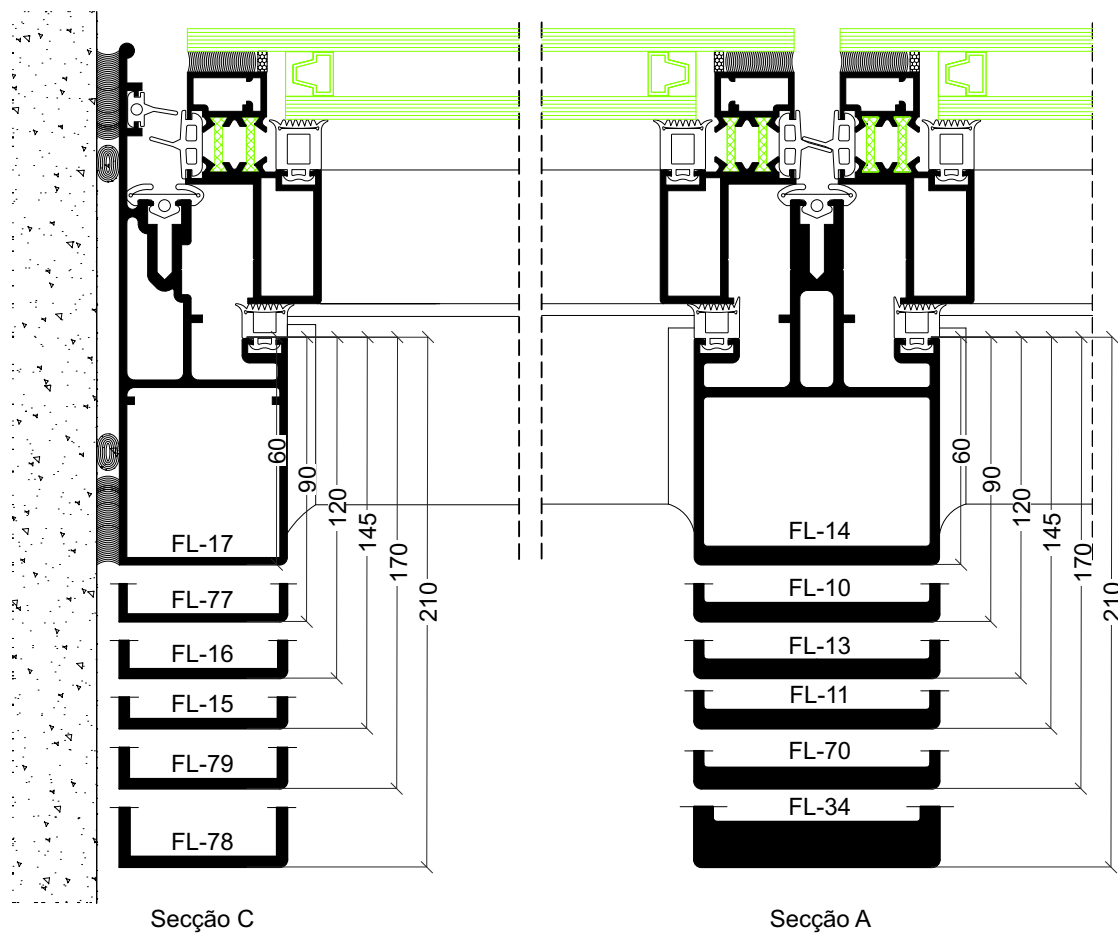

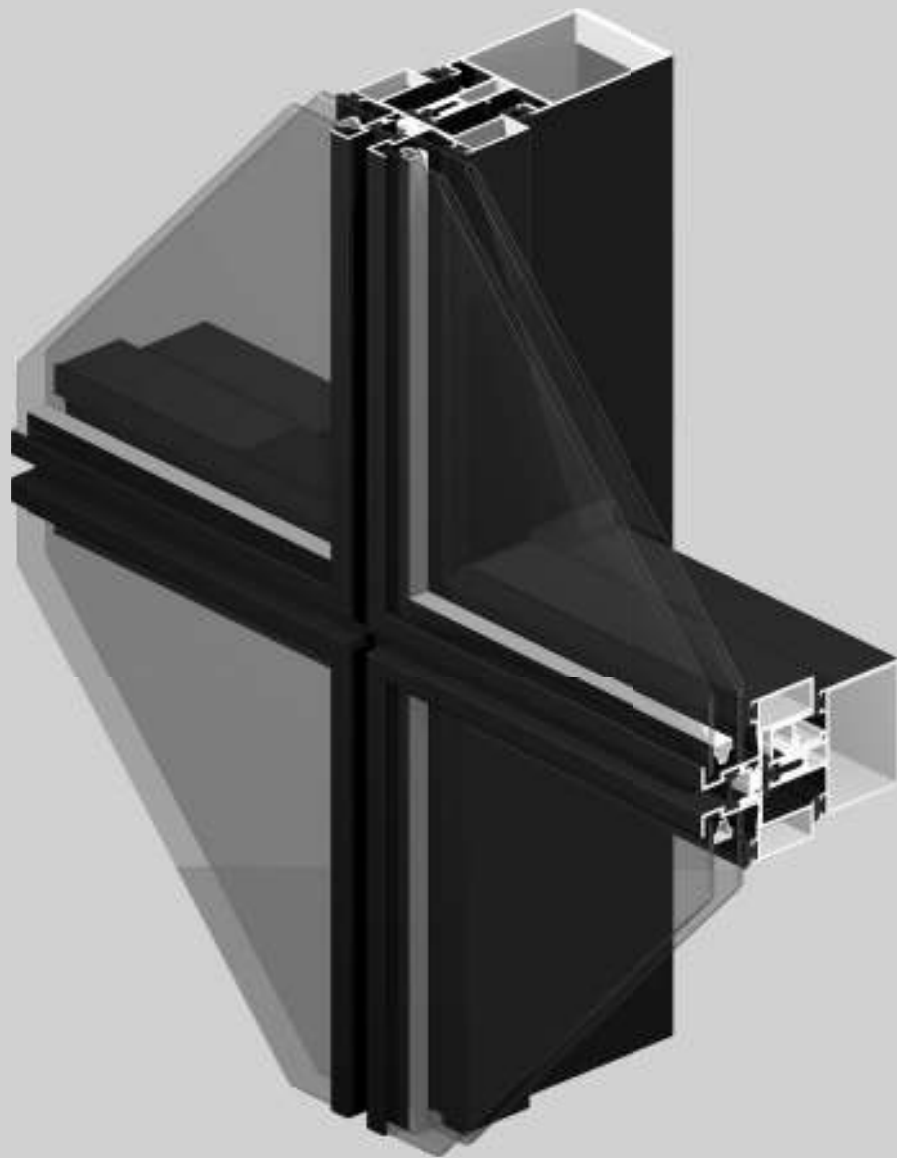

**Fachada  
Semi  
Estrutural**

## Fachada Semi-Estrutural

### Características

Sistema de fachada em que se utilizam perfis para o fabrico das folhas, com um aba que fixa o vidro, evitando o uso de silicone estrutural.

A secção da vista exterior deste sistema é de 12 mm ou 21 mm.

A secção dos montantes e travessas é de 65 mm, visíveis apenas do interior. Ambos os perfis apresentam canais de drenagem e ventilação que garantem juntamente com o sistema de juntas em EPDM, uma máxima estanquidade e permeabilidade. Possibilidade de perfis com rotura térmica.

### Possibilidades de abertura

Abertura projectante realizada por intermédio de compassos em aço inox com uma resistência até 180 kg, Tanto as folhas fixas como as projectantes são fabricadas com o mesmo perfil perimetral, tornando assim imperceptível a sua distinção pelo exterior.

**Pormenor horizontal e vertical**

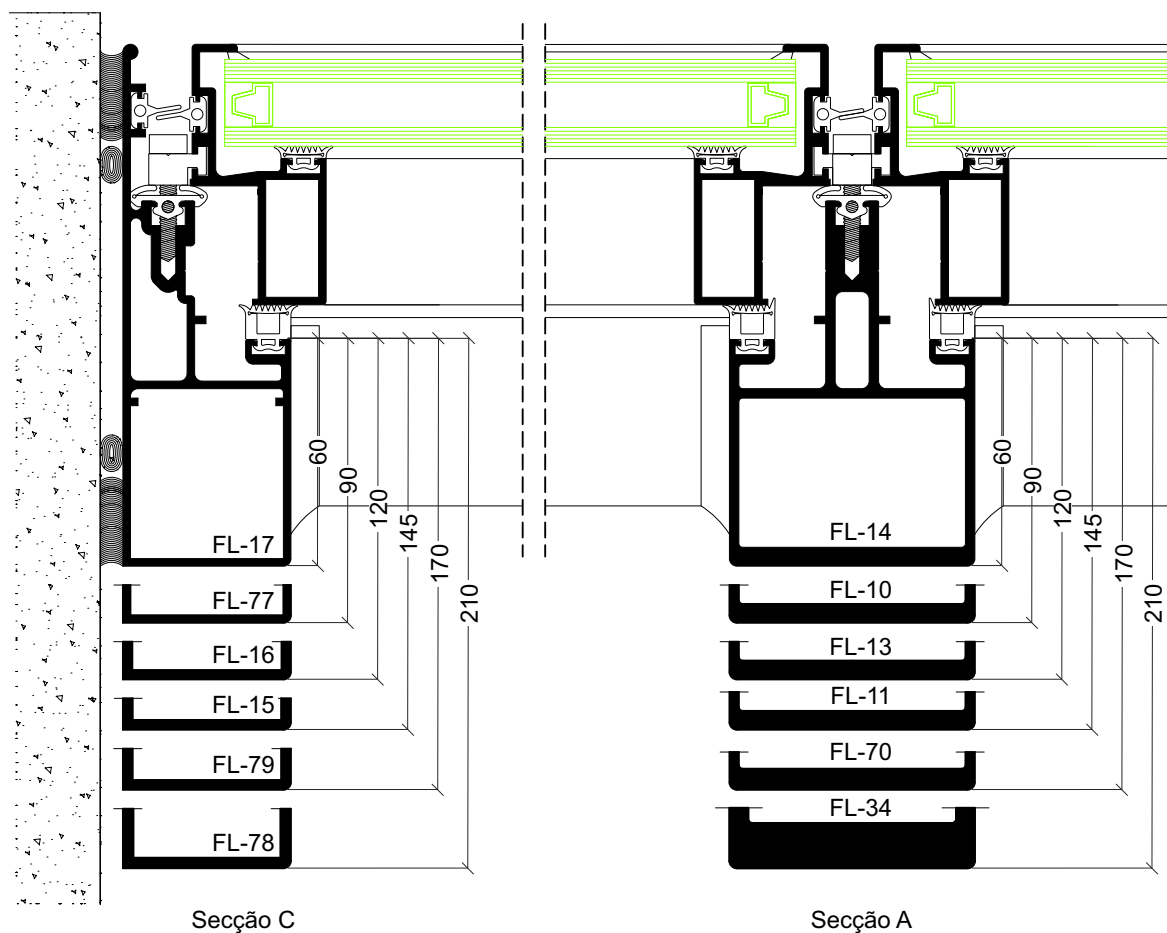
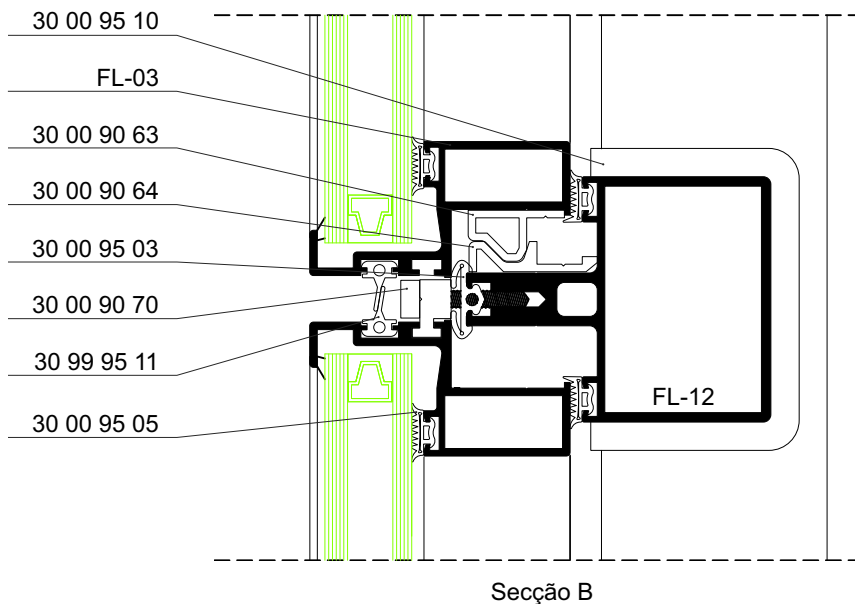
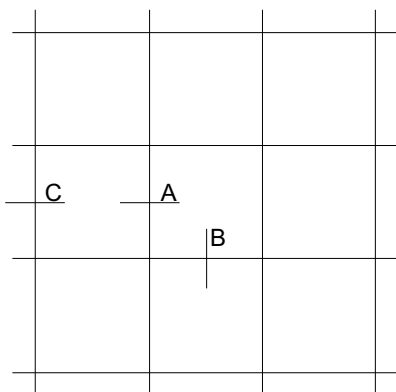

**Pormenor canto 90°**

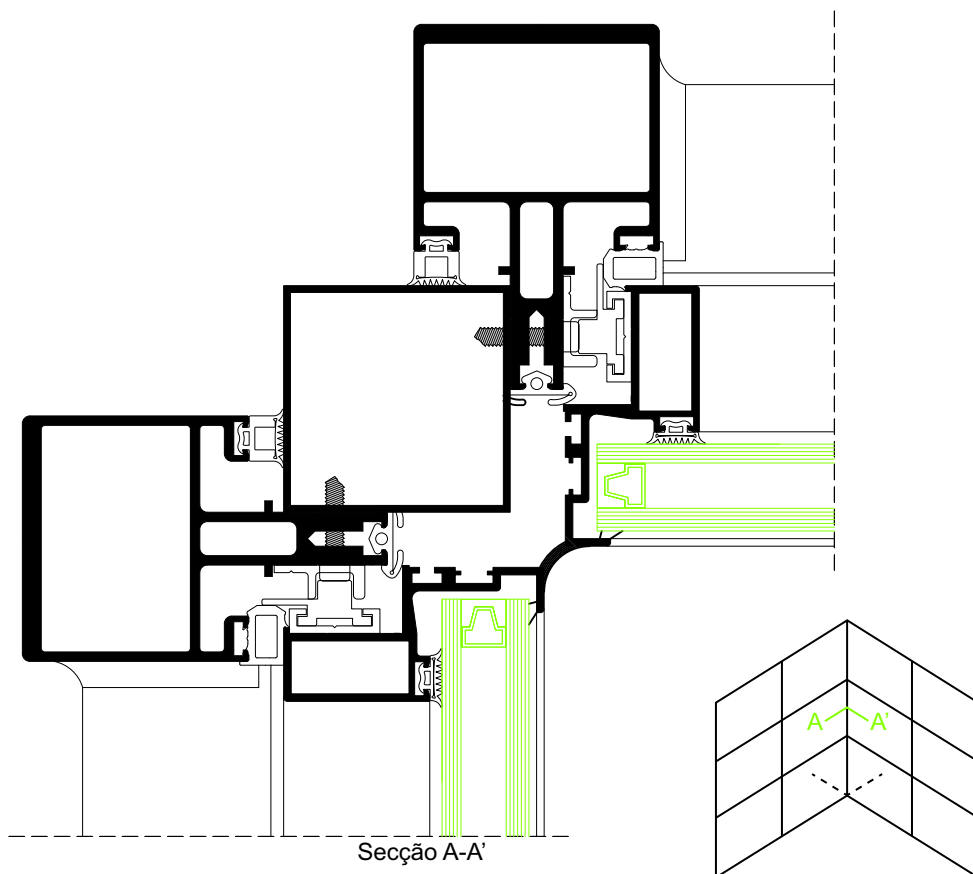

400

**Pormenor canto 90°**

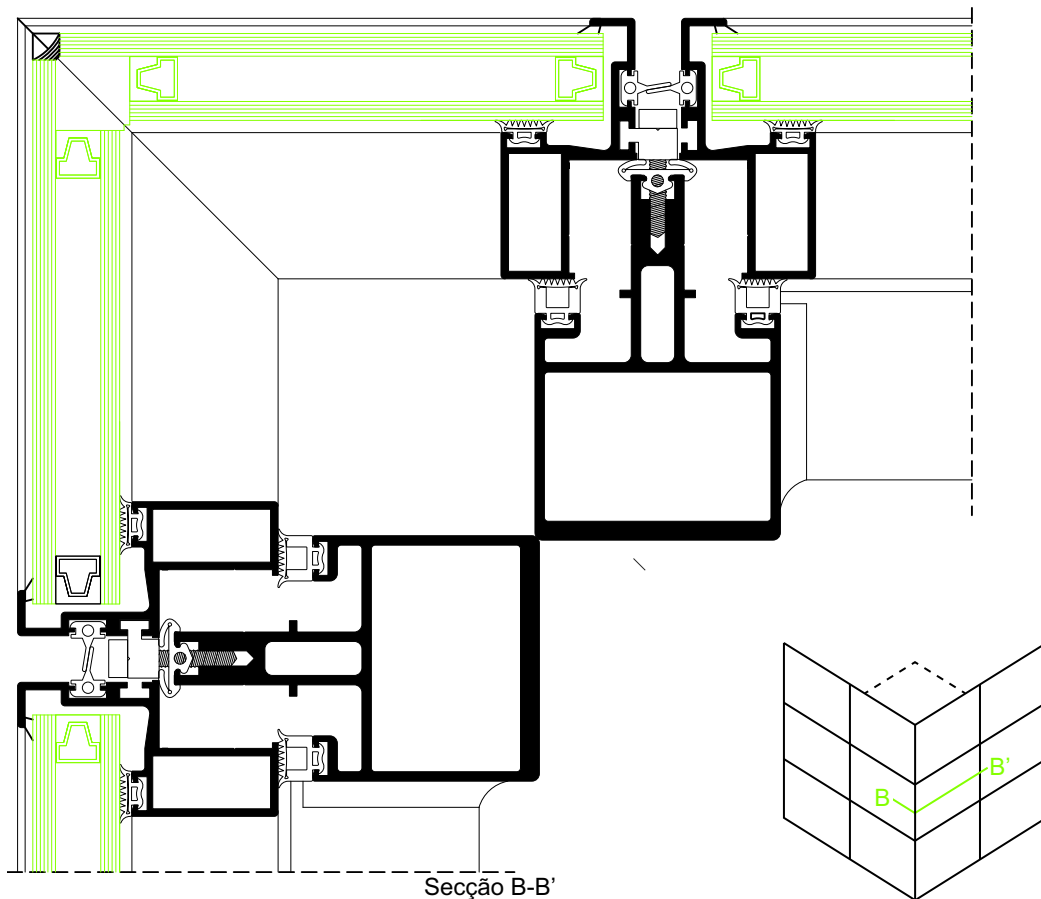

**Pormenor canto 90°**

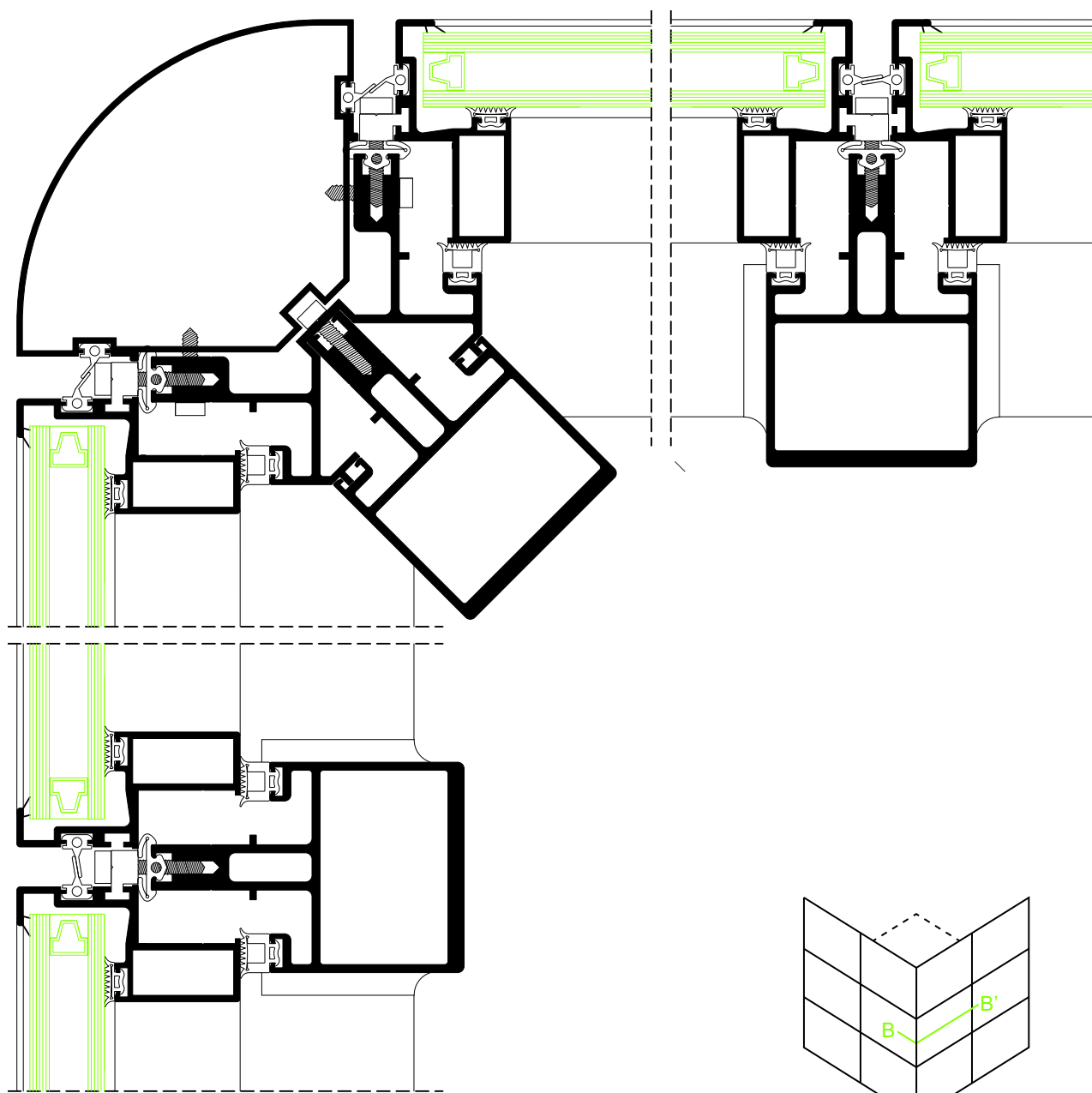

Secção A-A'

**Pormenor horizontal e vertical**

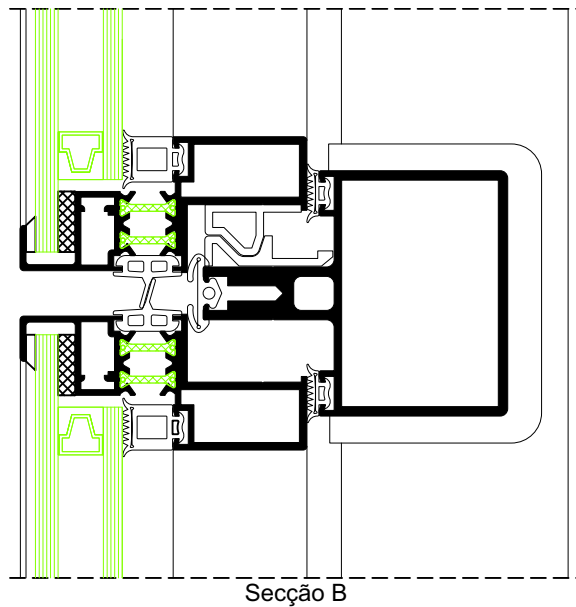
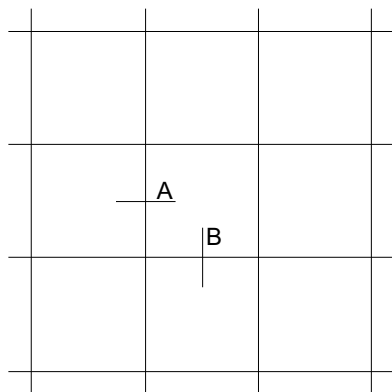

402

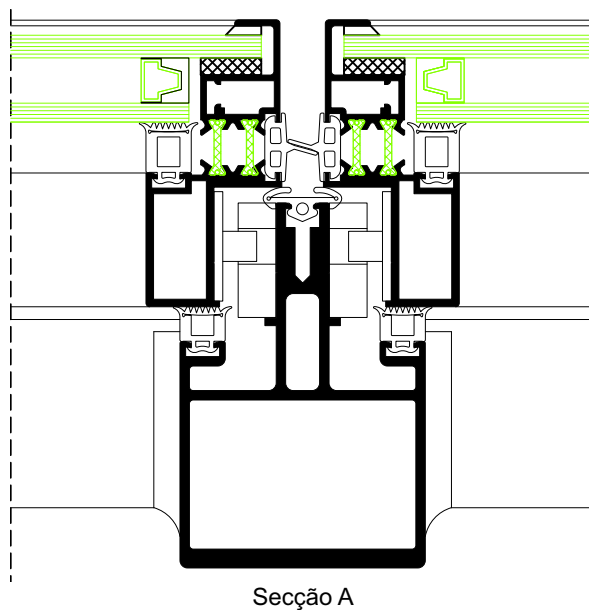



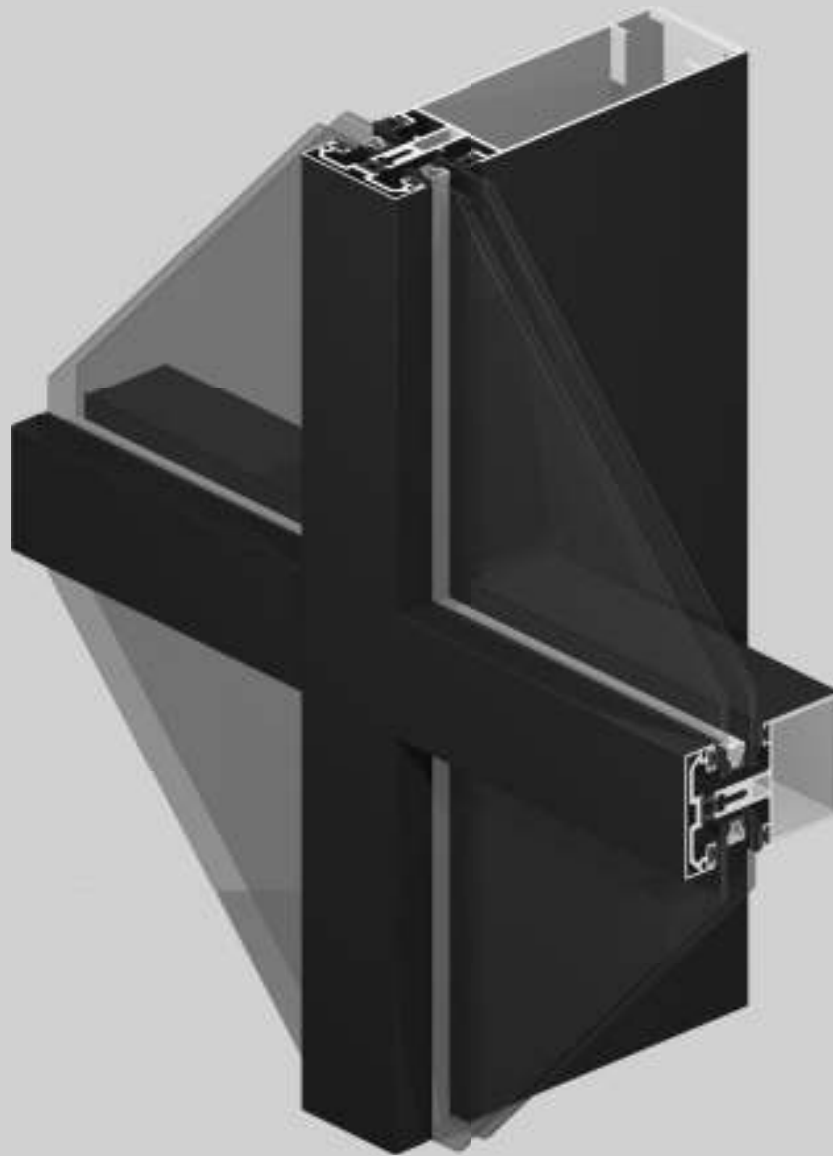

**Fachada  
Muro  
Invertido**

## Fachada Muro Invertido

### Características

Neste sistema a colocação de vidros realiza-se mediante uma contra-capa que fixa o vidro à estrutura portante. Sobre este perfil coloca-se uma capa exterior, horizontal e verticalmente, formando assim uma vista exterior nas duas dimensões. A secção visível no interior e exterior dos montantes e travessas é de 65 mm. Ambos os perfis apresentam canais de drenagem e ventilação que garantem juntamente com o sistema de juntas de EPDM, uma estanquidade e permeabilidade máximas.

### Possibilidades de abertura

Este tipo de fachada, ao contrário de todos os outros, permite qualquer tipo de abertura proporcionada pelos Sistemas Anicolor. A janela é fixa à estrutura com ajuda do perfil pressionante que fixa o vidro à fachada. Existe também a possibilidade de realizar aberturas projectantes "ocultas", isto é, não visíveis do exterior.

Categorias alcançadas em banco de ensaios:

1. Permeabilidade ao ar: Classe C
2. Estanquidade à água: 600 Pa
3. Resistência ao vento: 2400 Pa
4. Ensaio de segurança: 3600 Pa

## Fachada Muro Invertido – Tampa Elíptica

### Características

Sistema derivado da Fachada Muro Invertido mas que oferece uma estética exterior distinta. No sentido vertical, os vidros ocultam a estrutura portante, produzindo-se uma união vidro-vidro, enquanto que na horizontal, sobre o perfil pressionante que fixa o vidro, se coloca uma capa com forma elíptica ou redonda, realçando a vista horizontal deste tipo de fachadas. A secção visível, quer no interior, quer no exterior dos montantes e travessas é de 65 mm. Ambos os perfis apresentam canais de drenagem e ventilação que garantem, juntamente com o sistema de juntas de EPDM uma estanquidade e permeabilidade máximas.

### Possibilidades de abertura

Este tipo de fachada, ao contrário de todos os outros, permite qualquer tipo de abertura proporcionada pelos Sistemas Anicolor. A janela é fixa à estrutura com ajuda do perfil pressionante que fixa o vidro à fachada. Existe também a possibilidade de realizar aberturas projectantes "ocultas", isto é, não visíveis do exterior.

**Pormenor horizontal e vertical**

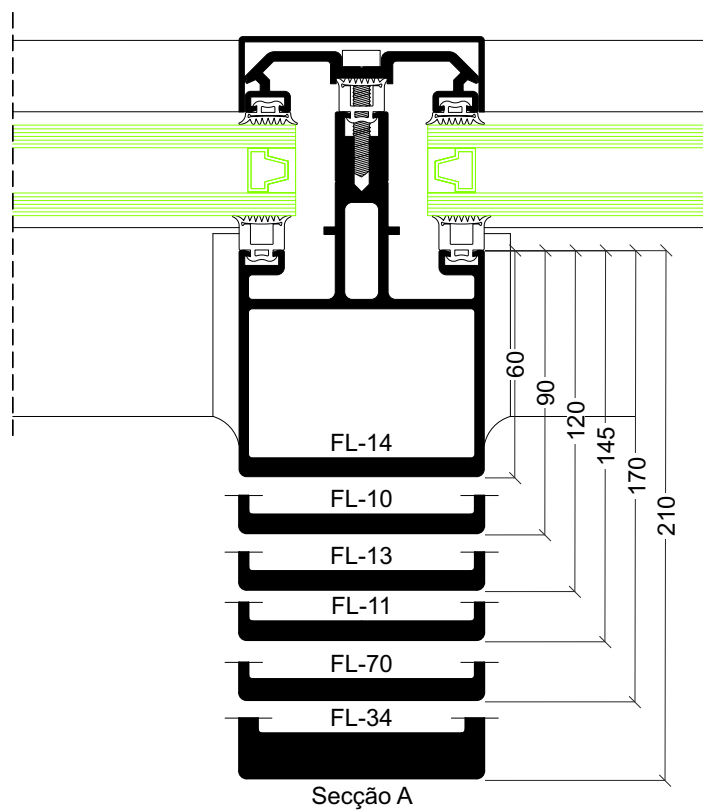
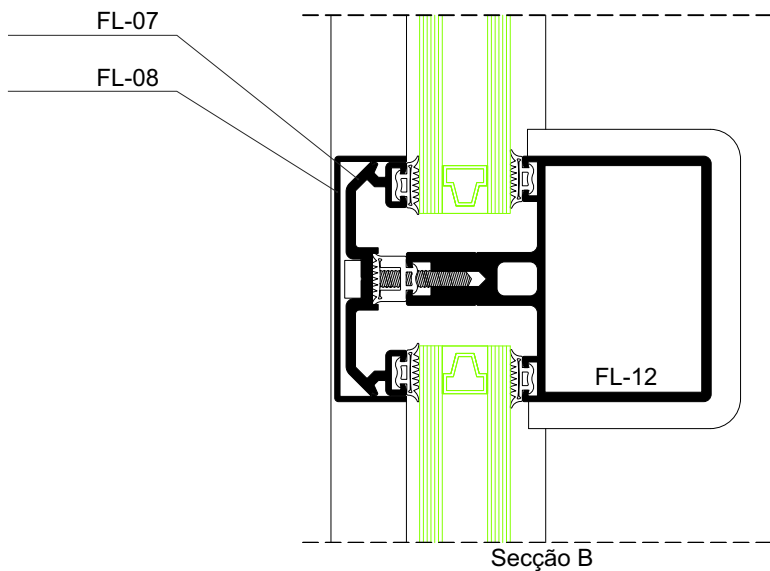
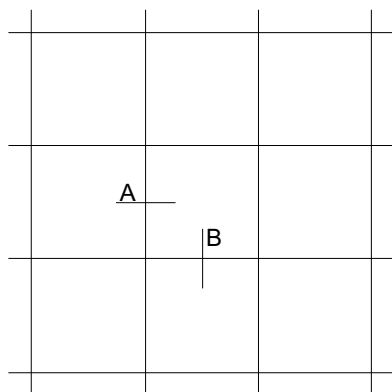

**Pormenor horizontal e vertical  
Janela projectante-deslizante (AXi)**

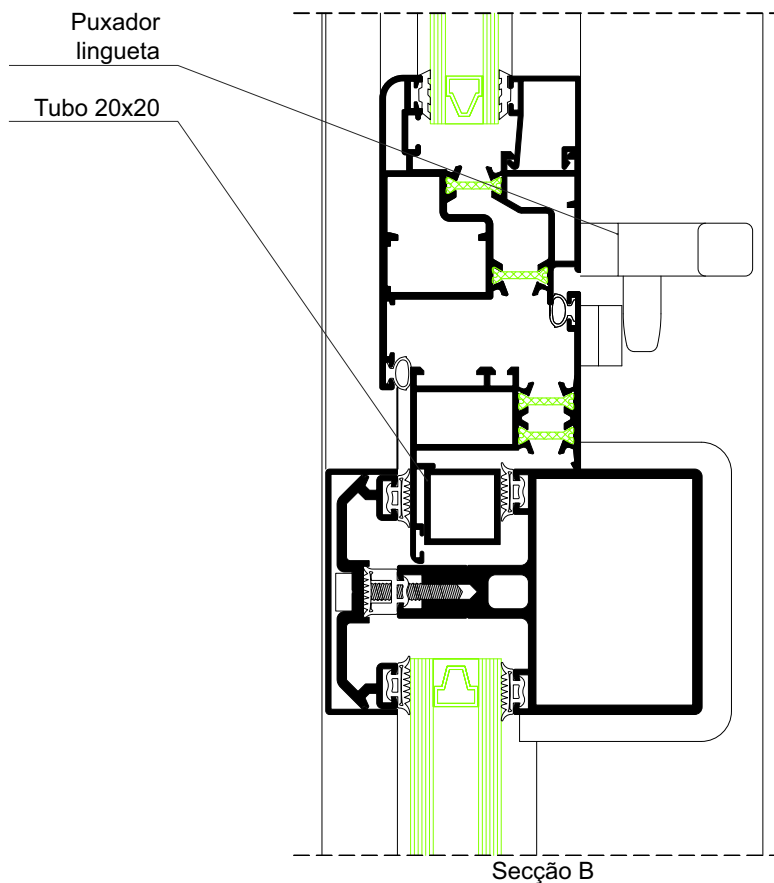
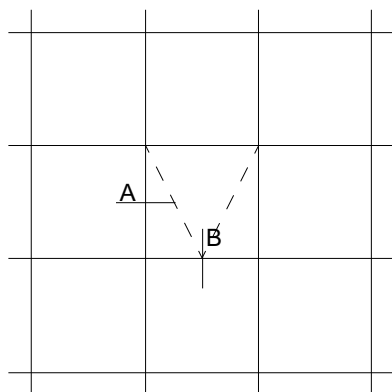

406

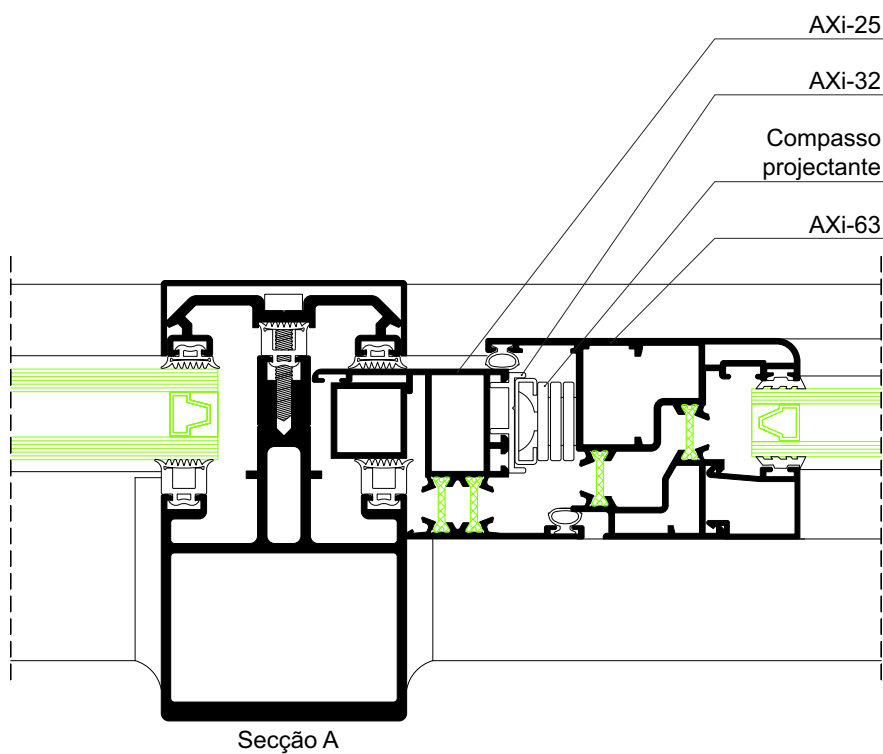

**Pormenor horizontal e vertical  
Janela projectante-deslizante (folha oculta)**

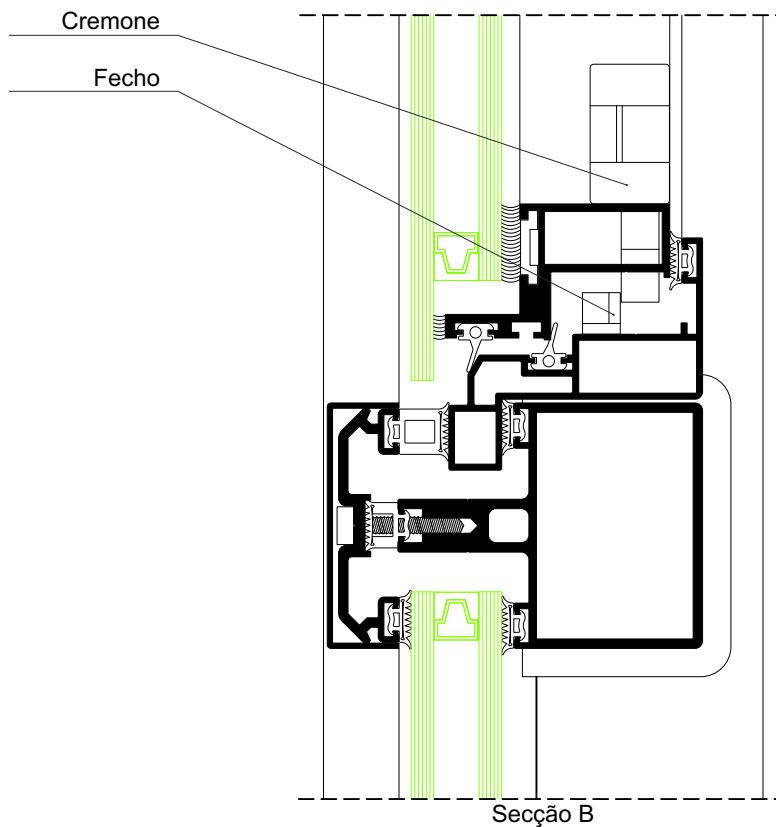
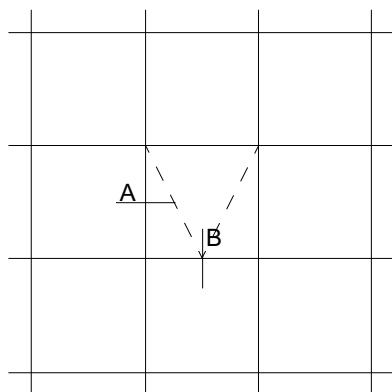

407

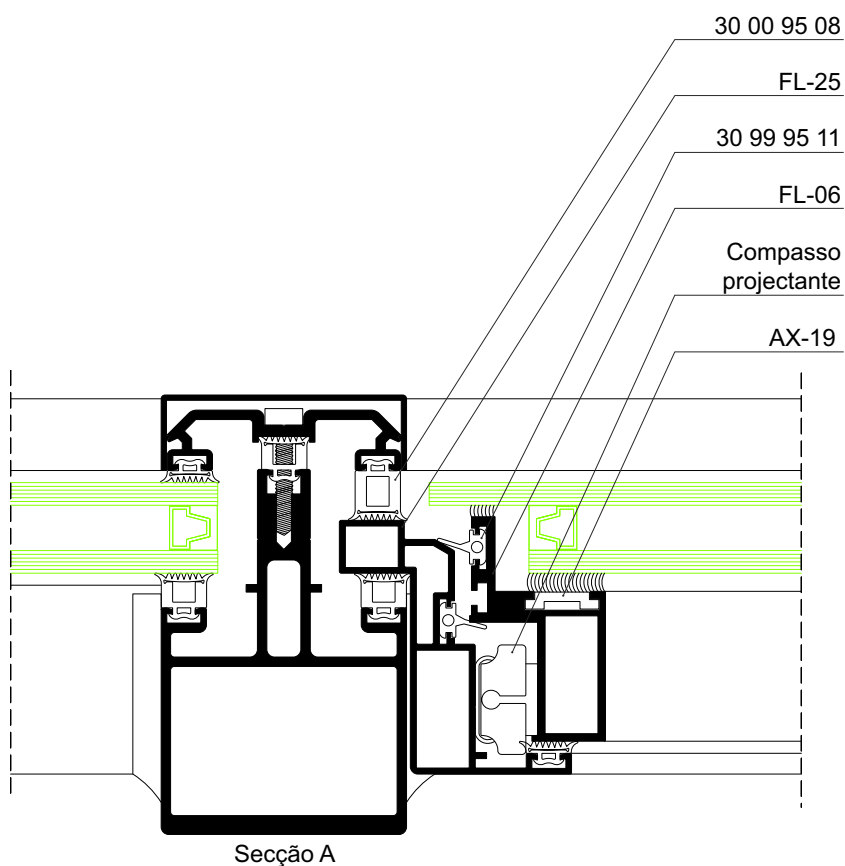

**Pormenor canto 90°**

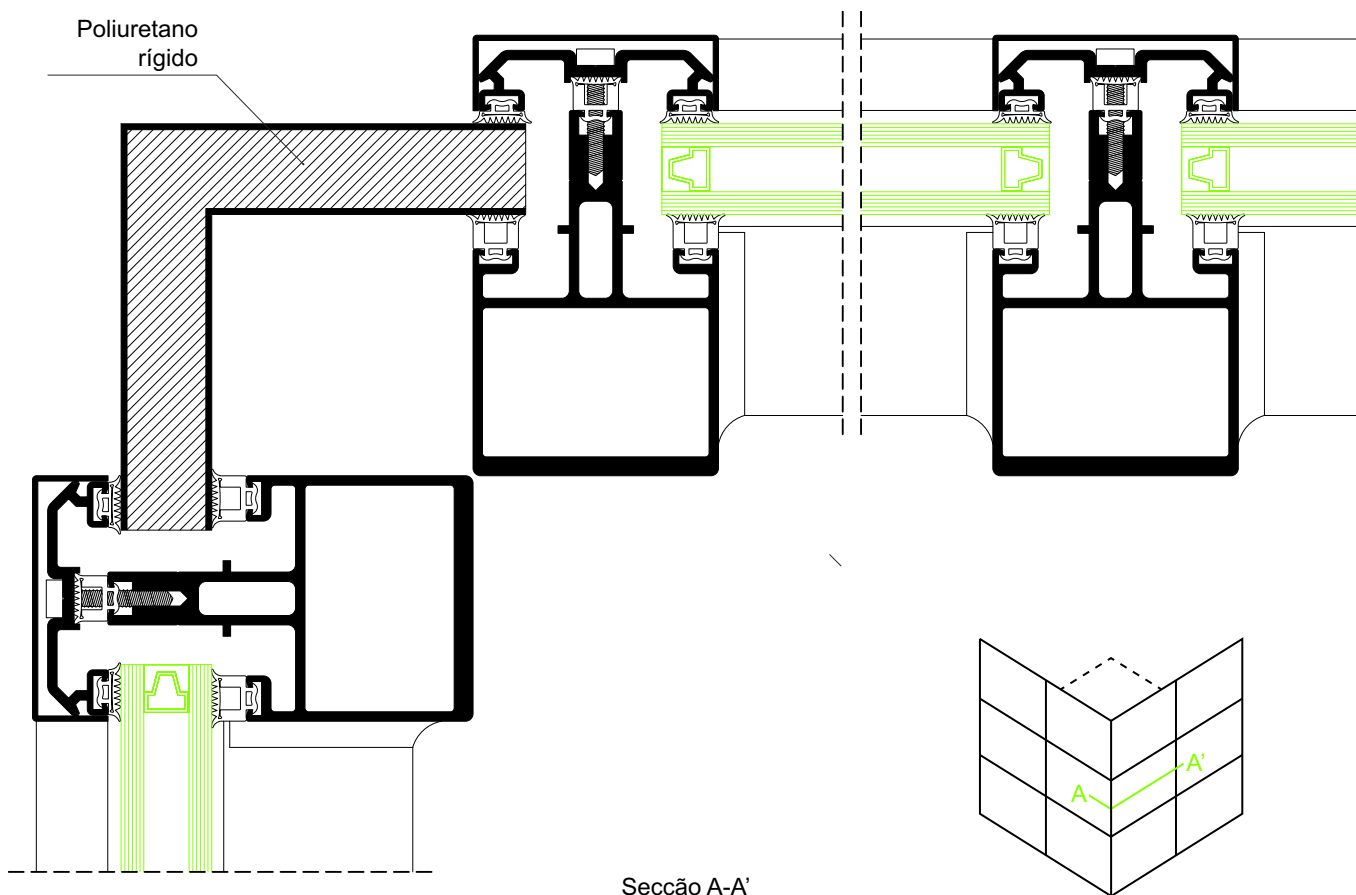

**Pormenor canto 90°**

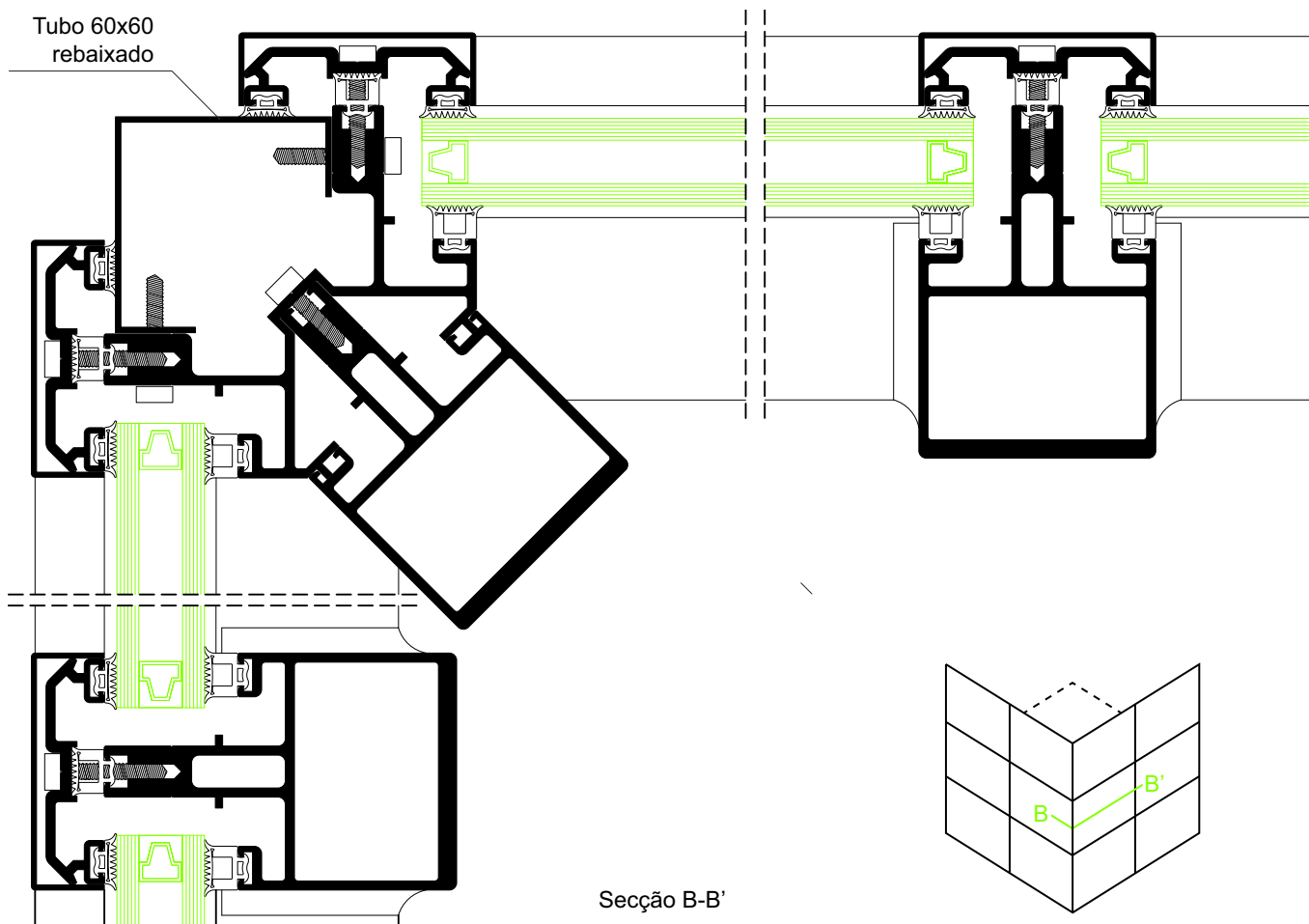

**Pormenor canto 90°**

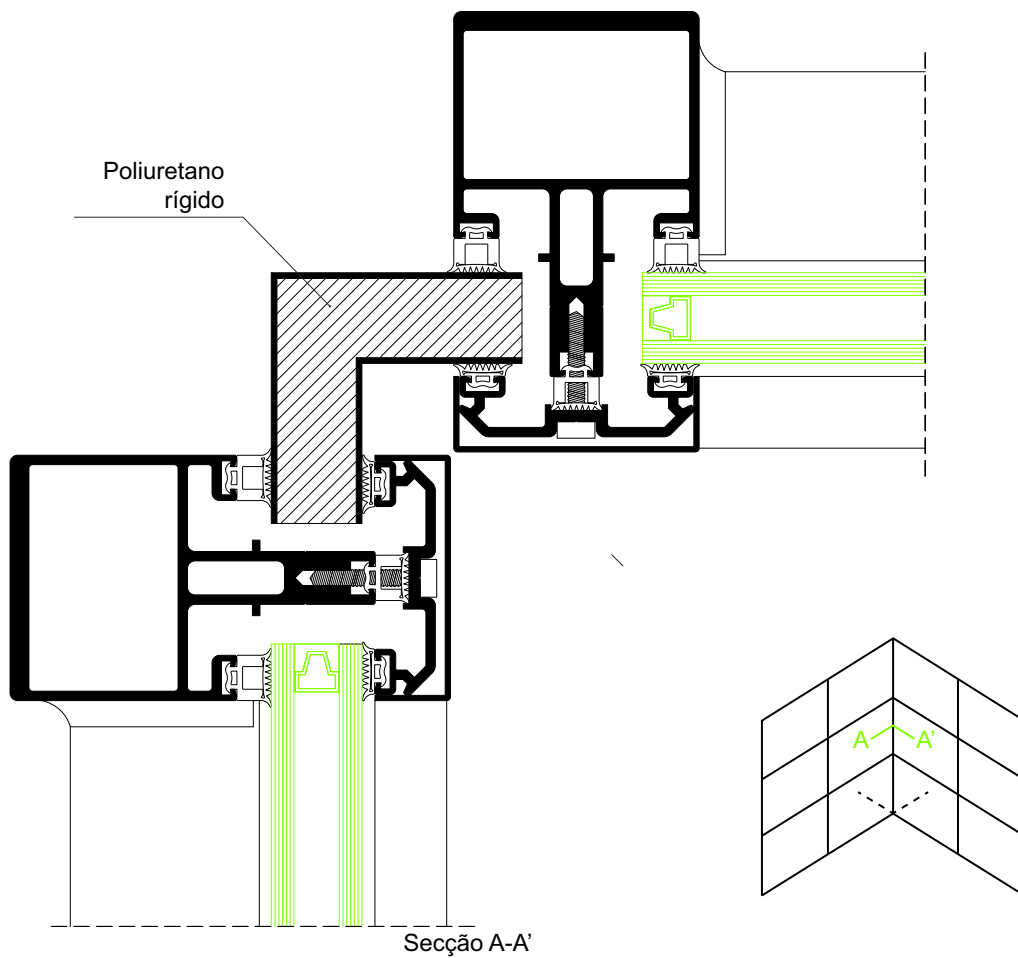

**Caixas de vidro**

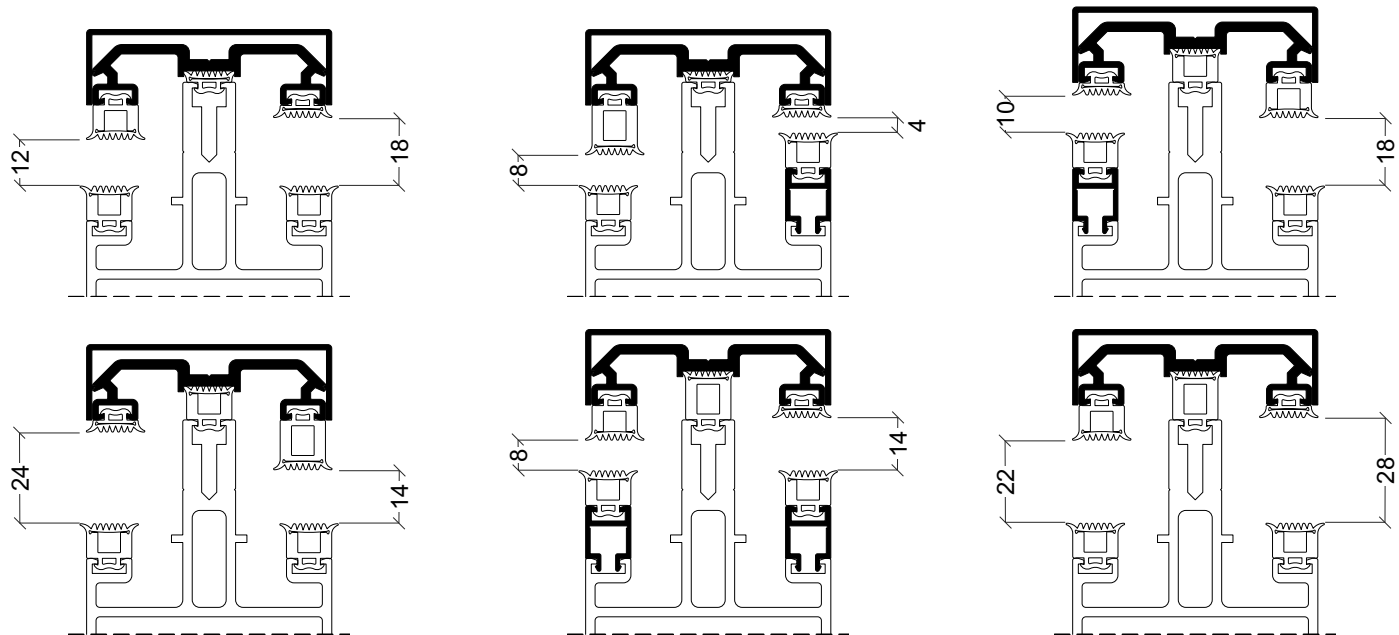

**Caixas de vidro**

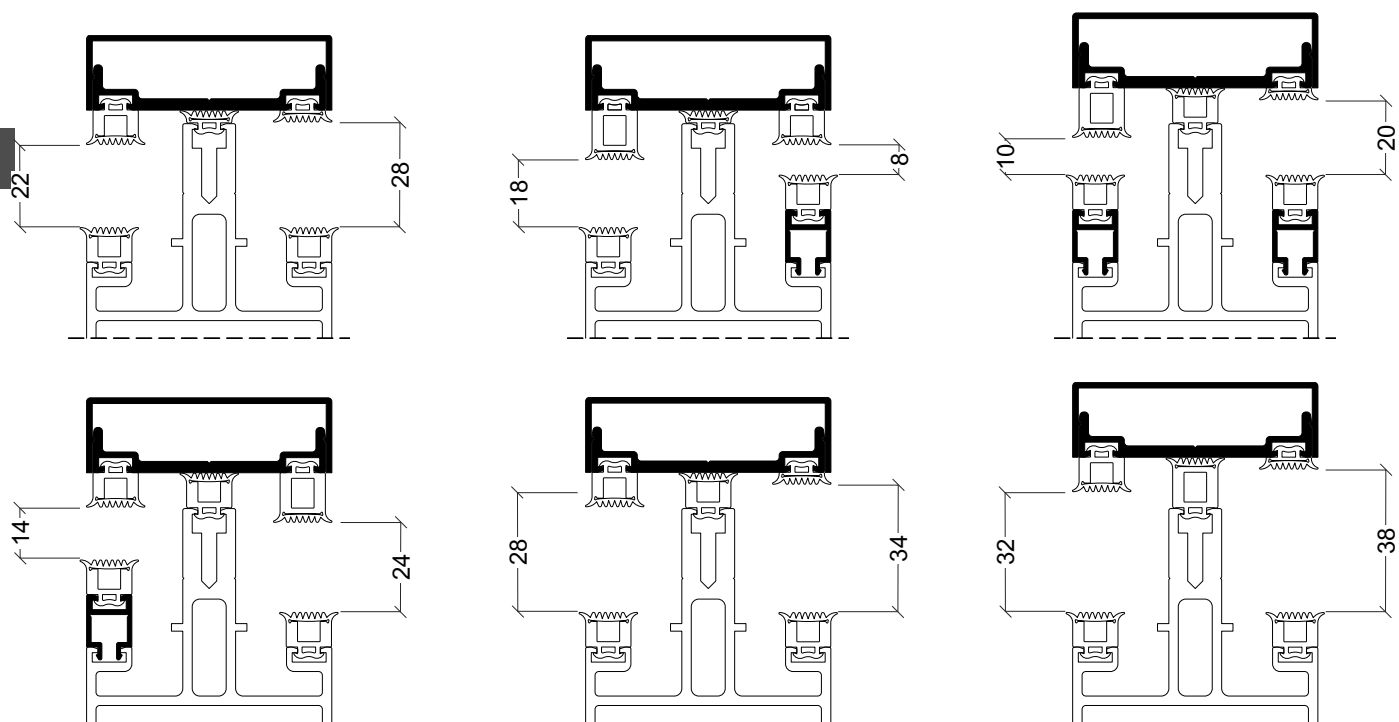

Referência	Desenho	Descrição
FL-32		Suplemento de muro invertido
30 00 95 01	11	Junta interior montante Junta central montante e travessa (muro invertido)
30 00 95 05	5	Junta interior de travessa
30 00 95 08	15	Junta central montante e travessa



**Pormenor horizontal e vertical**

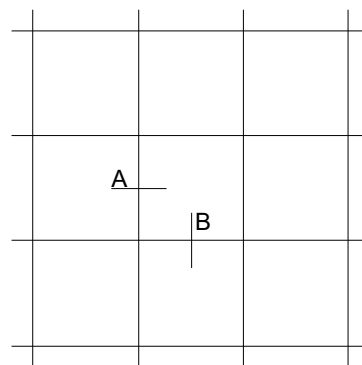
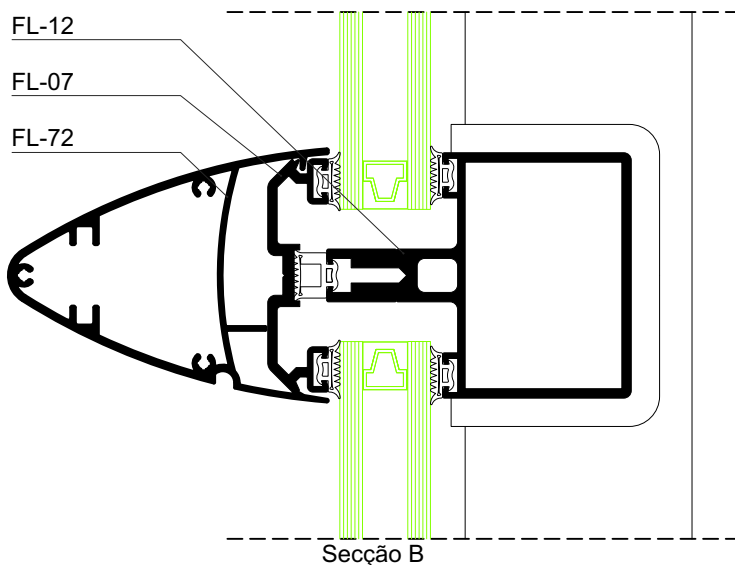
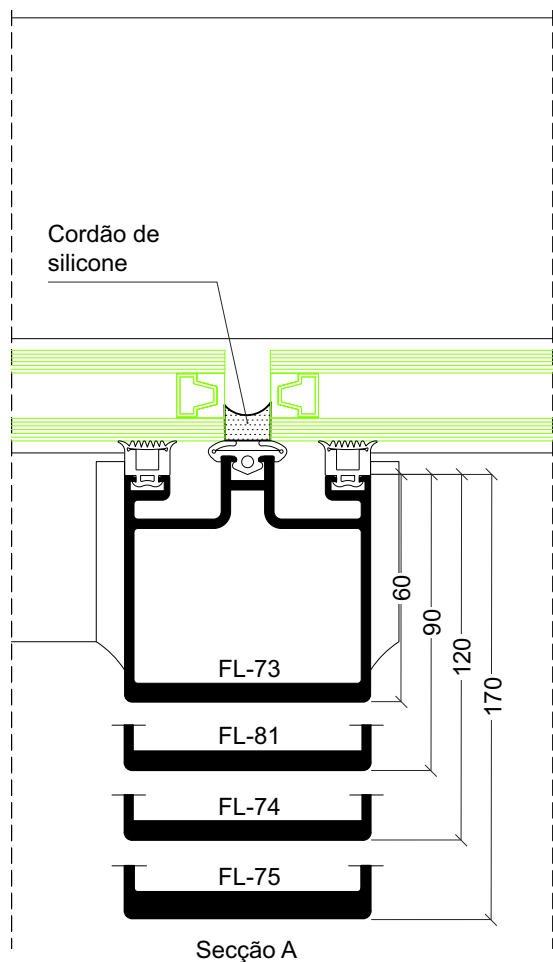

**Pormenor horizontal e vertical**  
**Janela projectante**

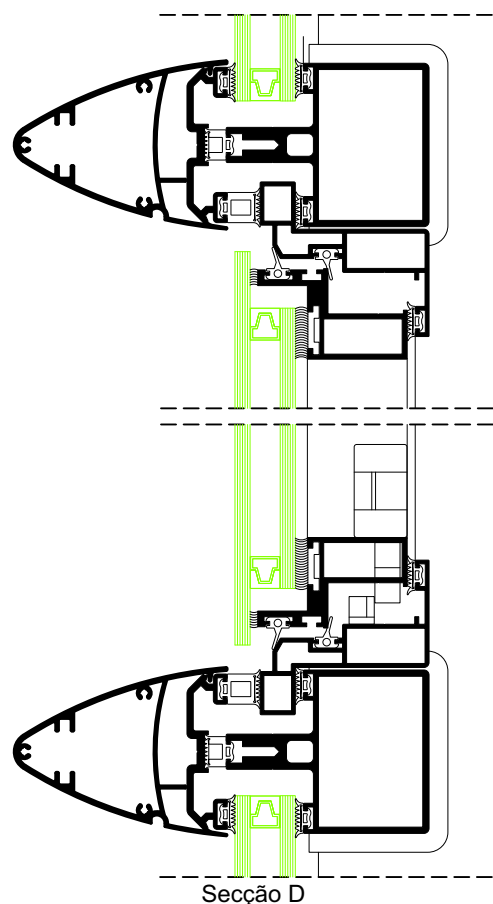
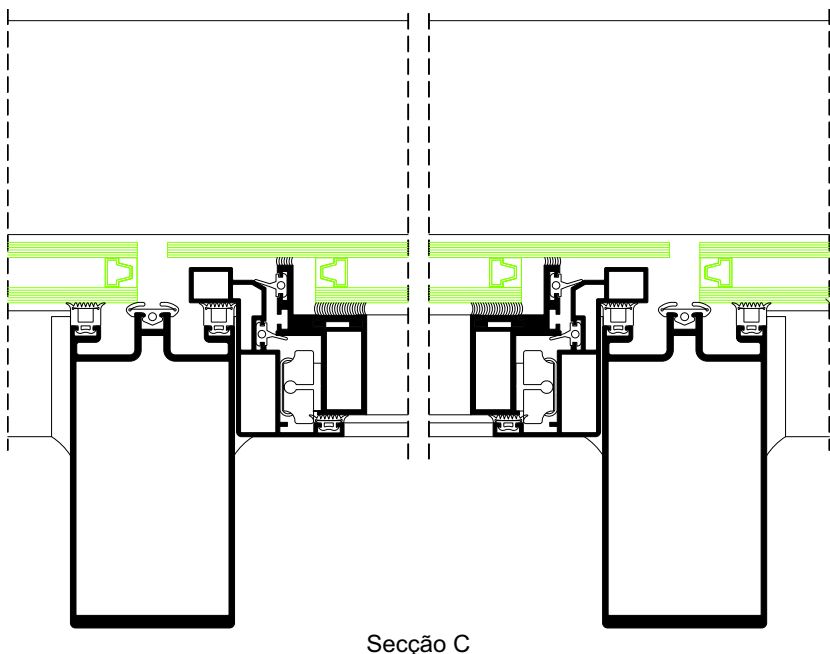
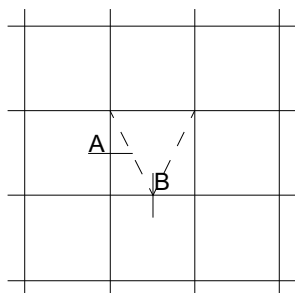

**Pormenor canto 90°**

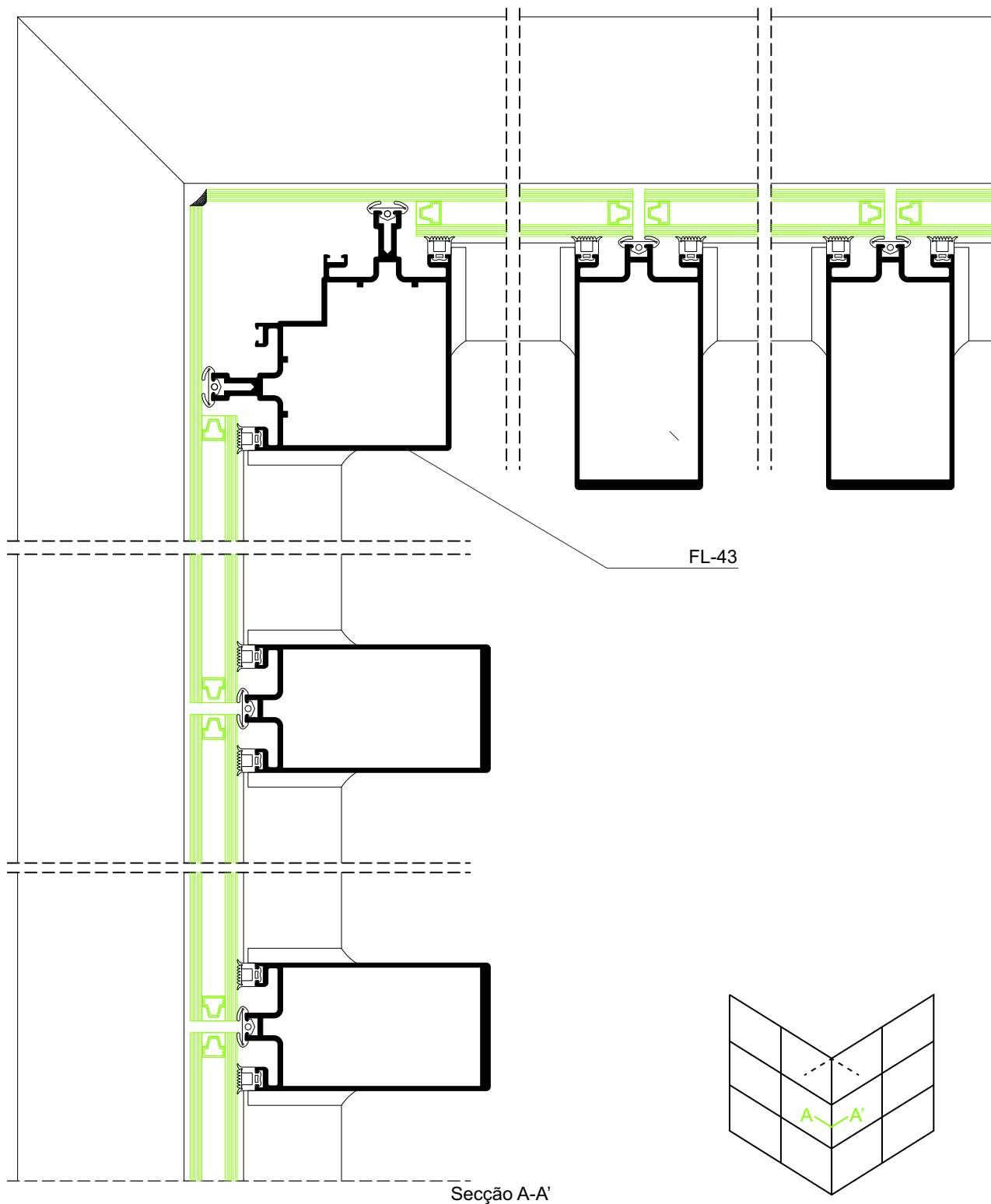

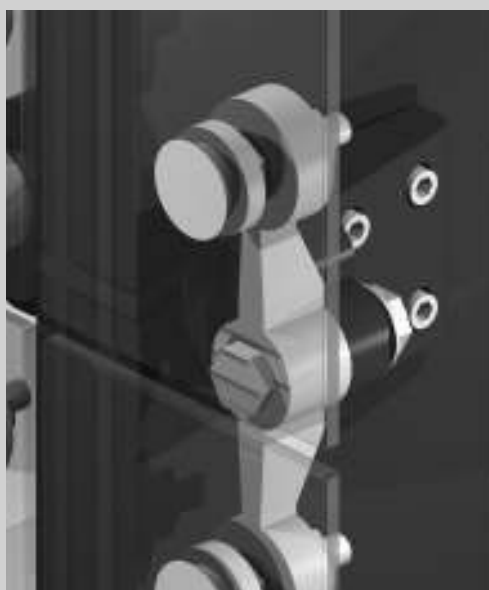
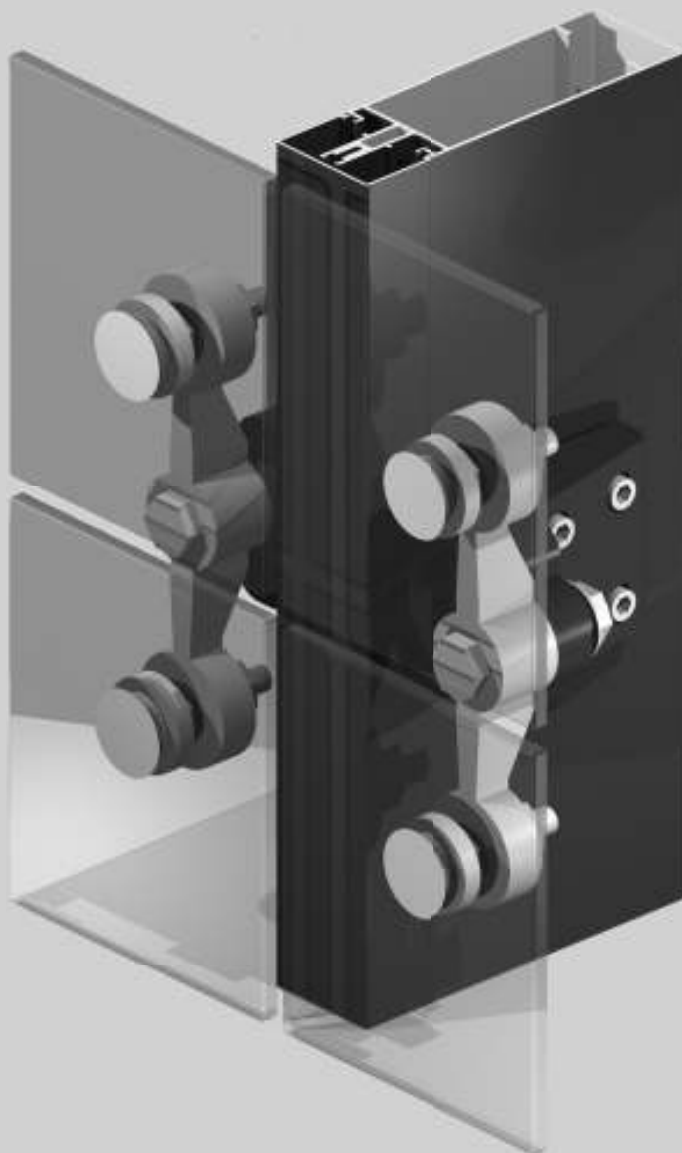

**Fachada  
Milénio**

## Fachada Milénio

### Características

Sistema de fachada ligeira, onde o vidro exterior é fixo mediante grampos e peças de fixação, fixas ou com rótulas. Os grampos, fabricados em aço inoxidável são fixos às peças de suporte do vidro. O vidro, temperado e/ou laminado é previamente mecanizado para permitir a sua fixação à estrutura. As peças de fixação apresentam as seguintes vantagens:

- facilitam a colocação do vidro;
- amortecem as deformações produzidas no vidro (pressão do vento, dilatações, ...);
- permitem corrigir defeitos construtivos.

A estrutura portante sobre a qual se fixam os grampos é formada por perfis verticais de alumínio com a elevada espessura de 65 mm de secção visível. Tal espessura confere a estes perfis um elevado momento de inércia, permitindo construções com grandes distâncias entre apoios. Este sistema complementa-se com outros perfis e juntas que permitem realizar as mais variadas soluções construtivas.

### Possibilidades de abertura

Este sistema não oferece possibilidade de abertura.

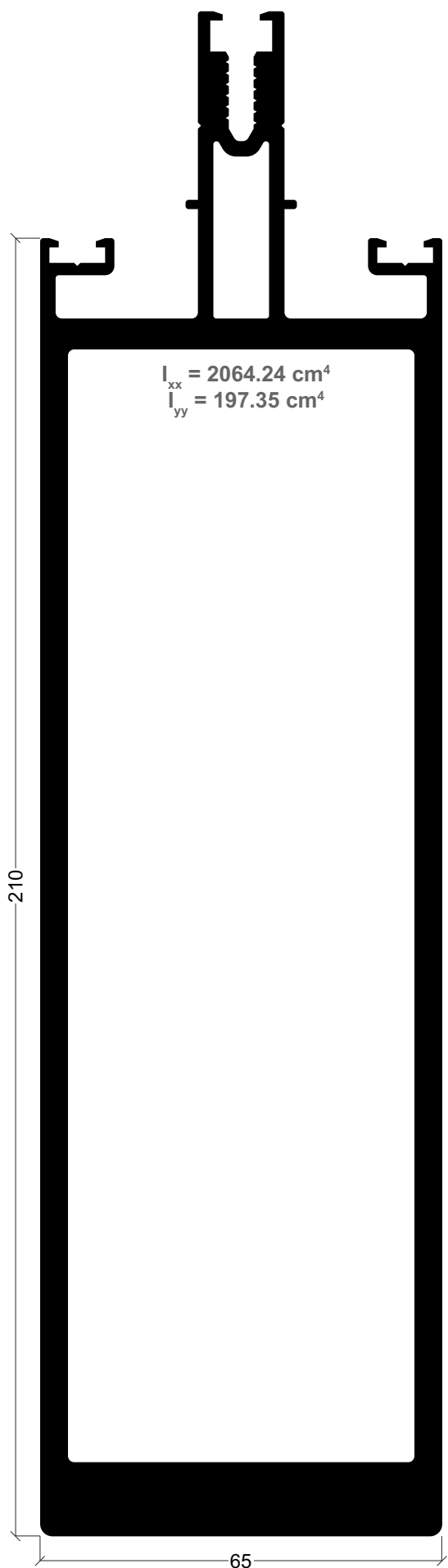

**FL-34**  
Montante de 210 mm

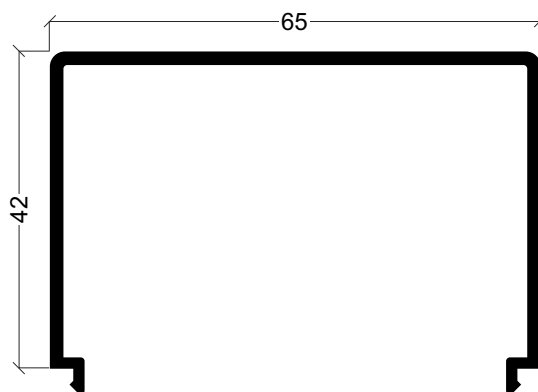

**FL-53**  
Remate topo de montante

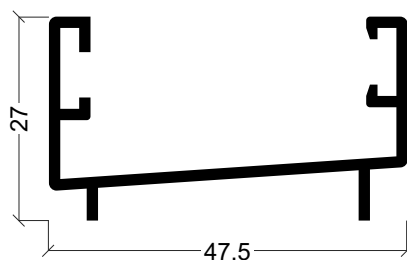

**FL-54**  
Remate

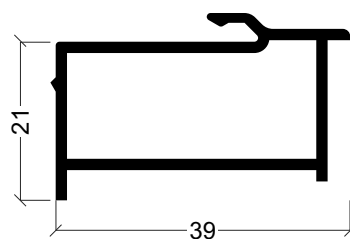

**FL-55**  
Porta-vedante

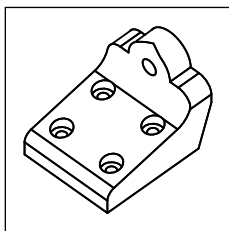

**30 20 96 01**

Suporte do vidro

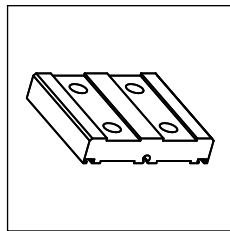

**30 20 96 02**

Contra-placa

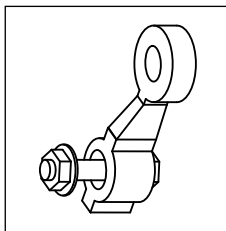

**30 20 96 03**

Grampo 1 (45°) (peso vidro máx. 300 kg)

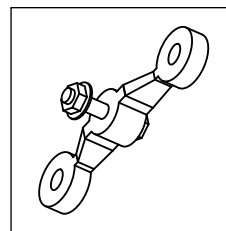

**30 20 96 04**

Grampo 2 (180°) (peso vidro máx. 300 kg)

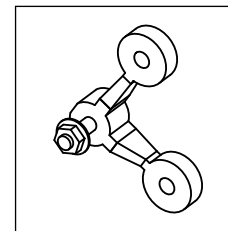

**30 20 96 05**

Grampo 3 (90°) (peso vidro máx. 300 kg)

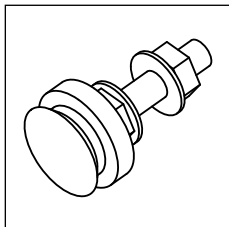

**30 20 96 06**

Rótula  
(vidro monolítico 8-12 mm)  
(vidro laminado 8-12 mm / 6-15 mm)

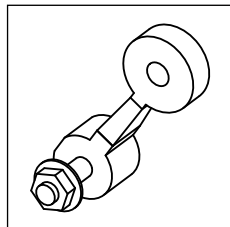

**30 20 96 09**

Grampo 4 (0°) (peso vidro máx. 300 kg)

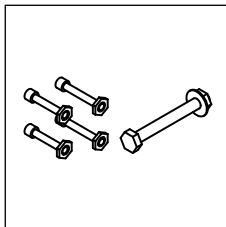

**30 27 96 01**

Kit de fixação

Referência	Desenho	Descrição
30 20 96 07		Junta de remate
30 20 96 08		Junta entre vidros

### Pormenor horizontal

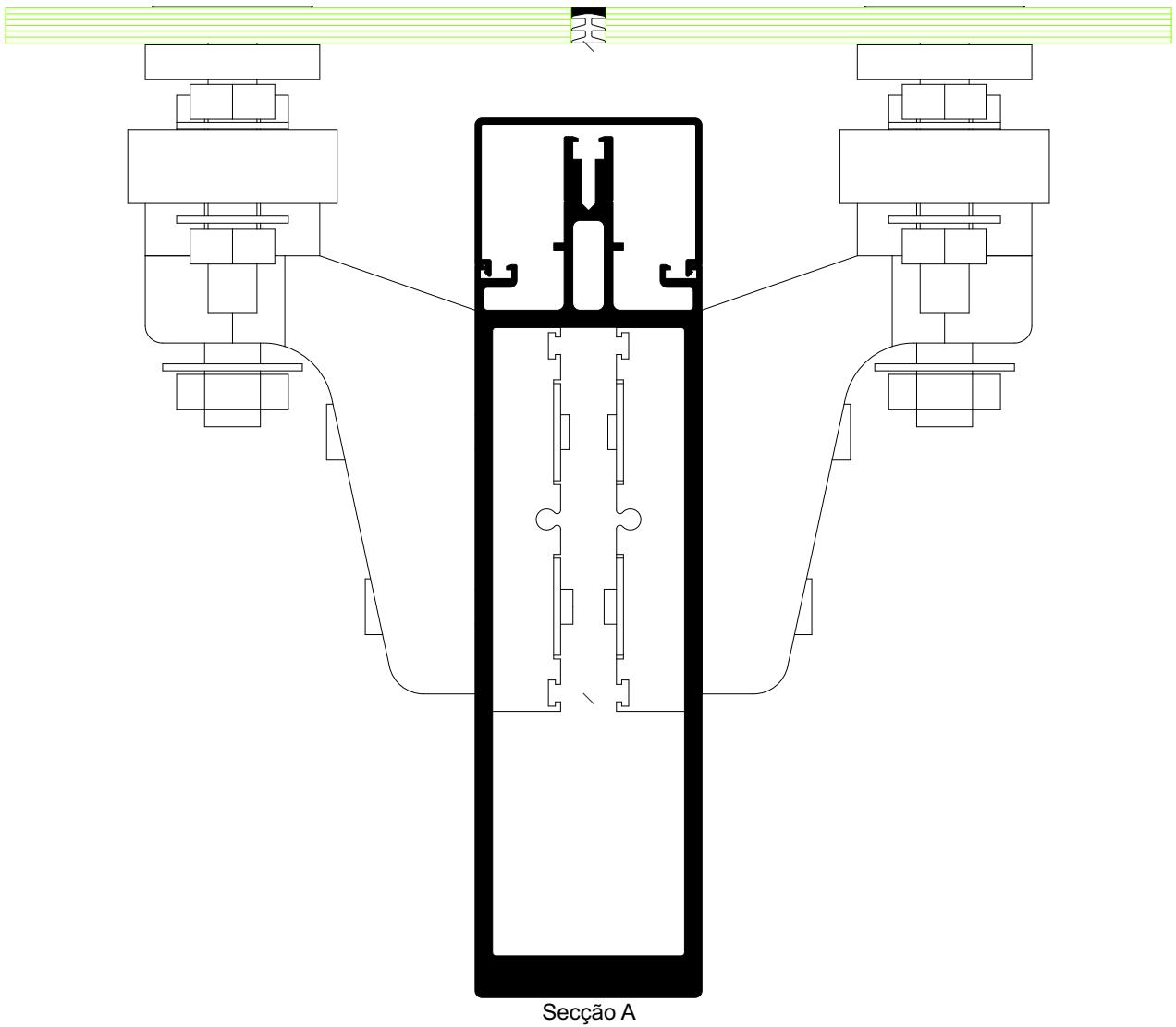
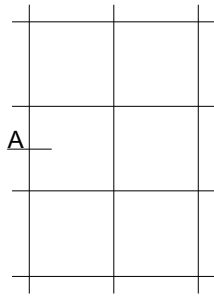

**Pormenor vertical**

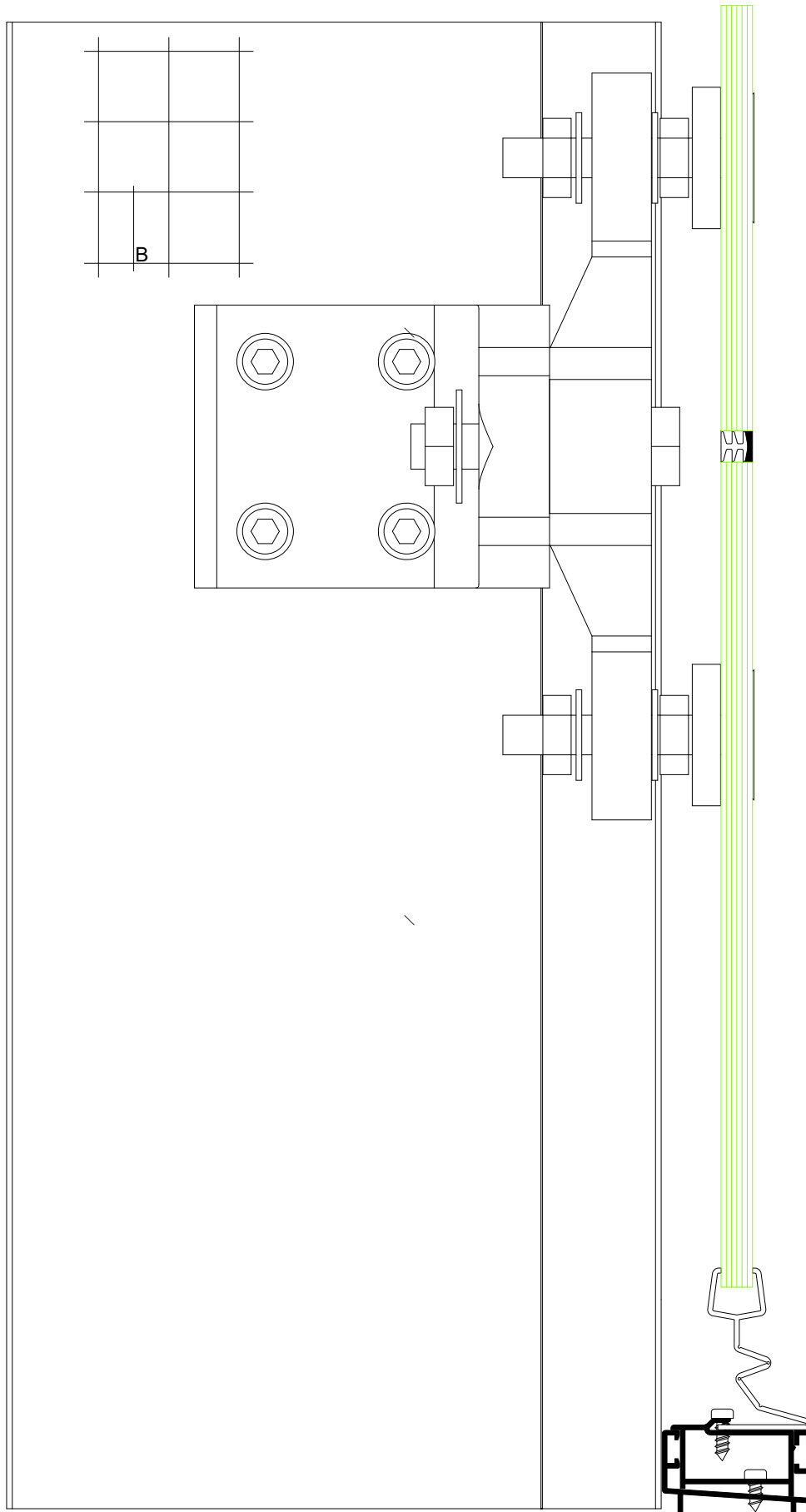

Secção B



### Pormenor canto 90°

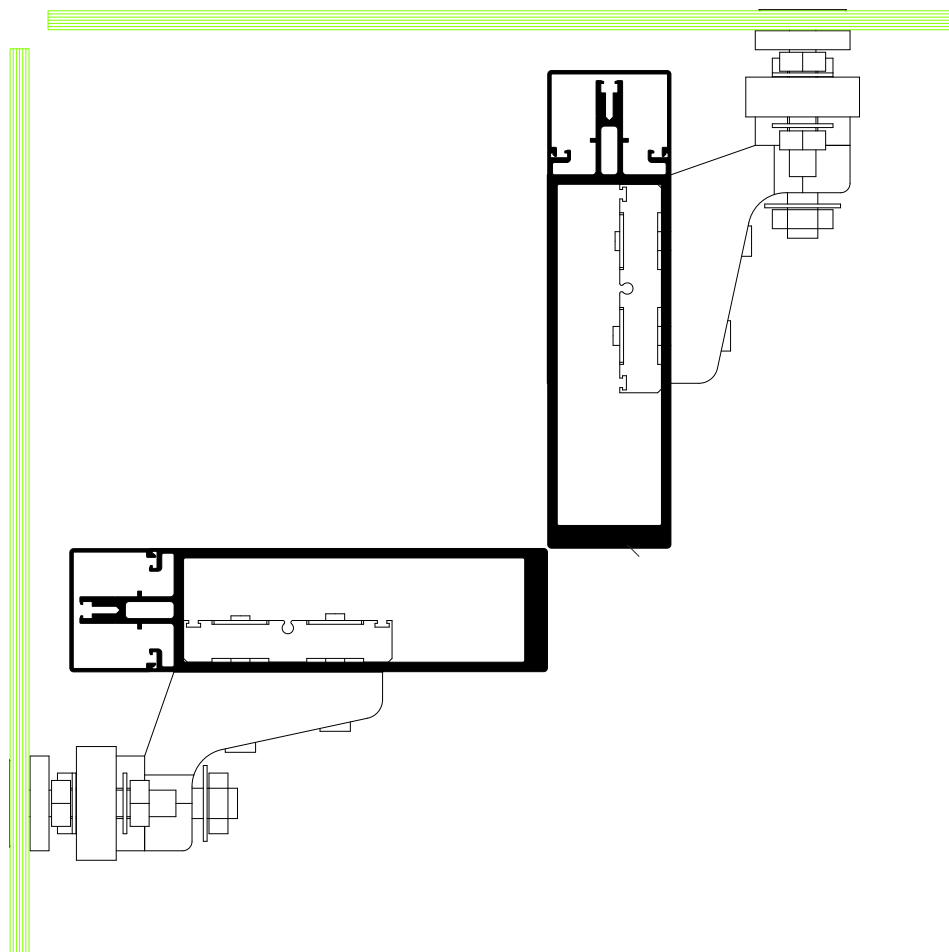
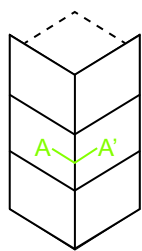

Secção A-A'

### Pormenor canto 90°

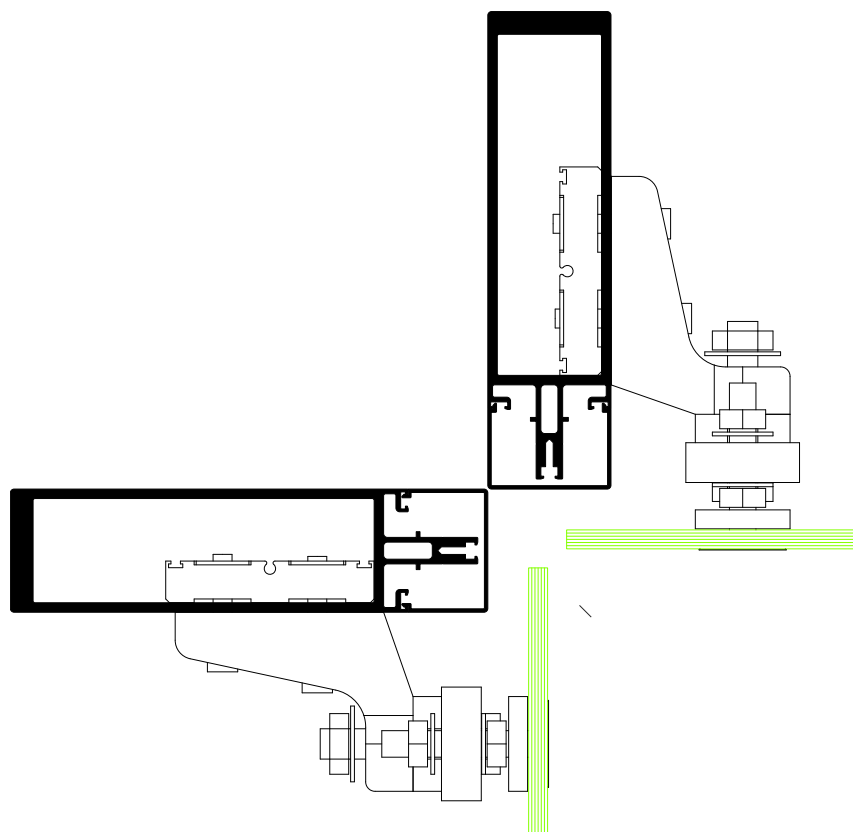
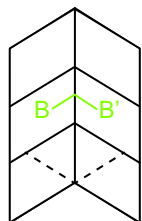

Secção B-B'

### Pormenor horizontal

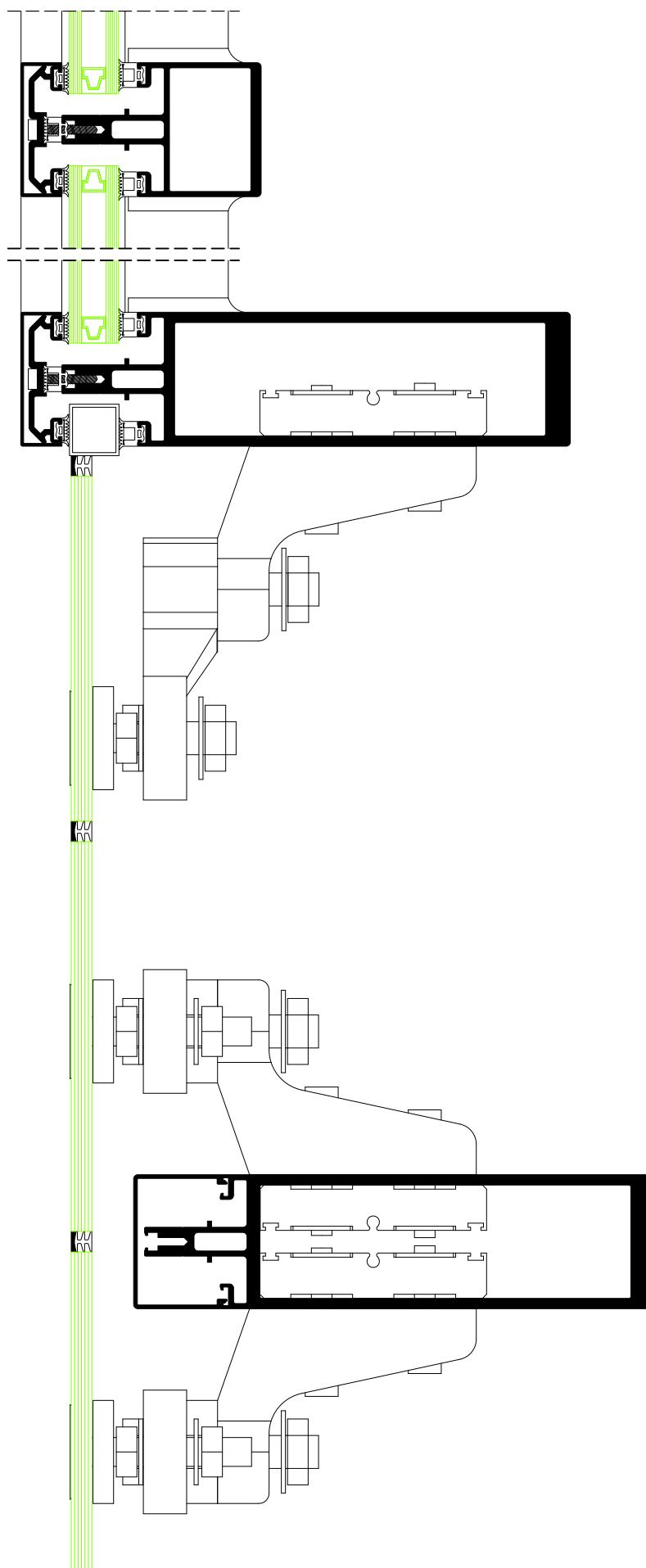

420

Seção A-A'



**Sistema Ergolux**

## Sistema Ergolux

### Características

Este sistema utiliza o princípio fundamental de canais de drenagem e ventilação dos sistemas de fachada. Complementa-se com perfis que permitem adoptar distintas soluções, tanto em clarabóias como em varandas. Podem assim gerar-se novos espaços com grande luminosidade.

Os perfis deste sistema têm uma secção visível interior de 65 mm, enquanto que a sua profundidade varia segundo as necessidades do cálculo estático (estrutura portante, carga de neve, zona eólica, etc.) Do mesmo modo, existe uma grande gama de capas pressionantes do vidro com várias possibilidades de ajuste, permitindo assim que se consigam os ângulos necessários para cada caso. Este sistema, aplicado em coberturas ou solários, contém perfis de ligação com e sem rotura térmica, que permitem a utilização de qualquer tipo de abertura. A total estanquidade do sistema é garantida pelo conjunto de juntas em EPDM, resistentes aos agentes atmosféricos.

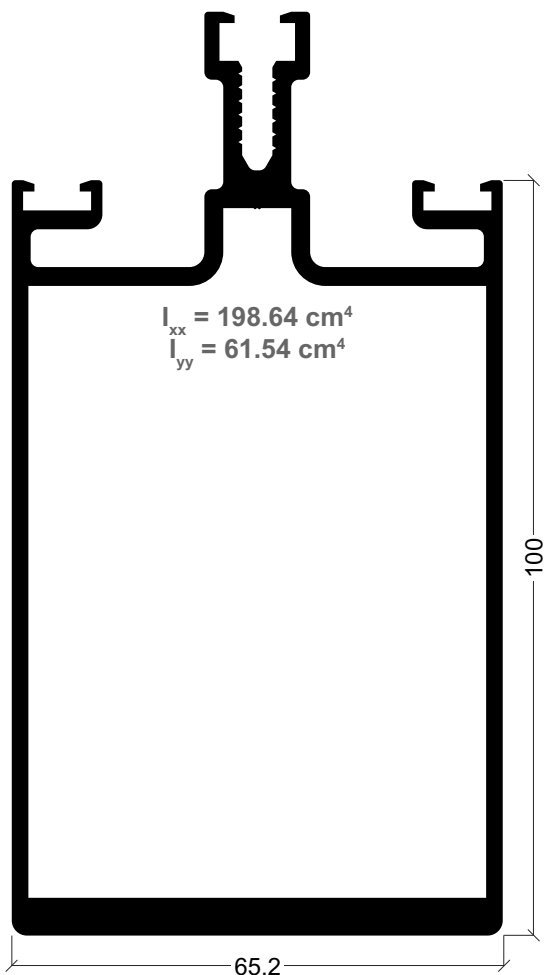

**FL-41**  
Montante 100 mm

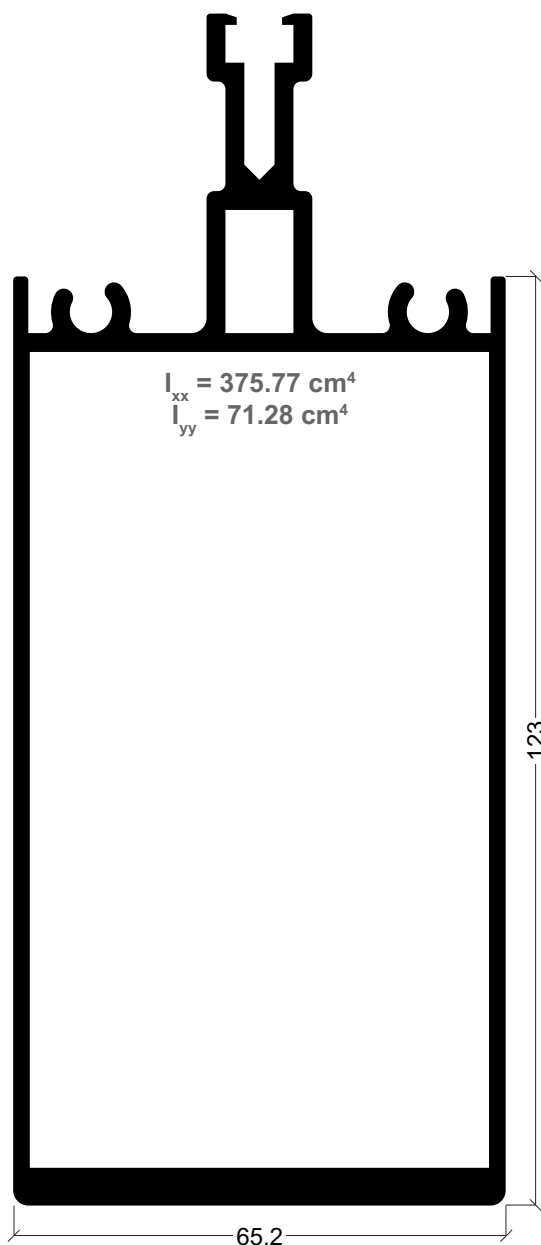

**FL-56**  
Montante regulável

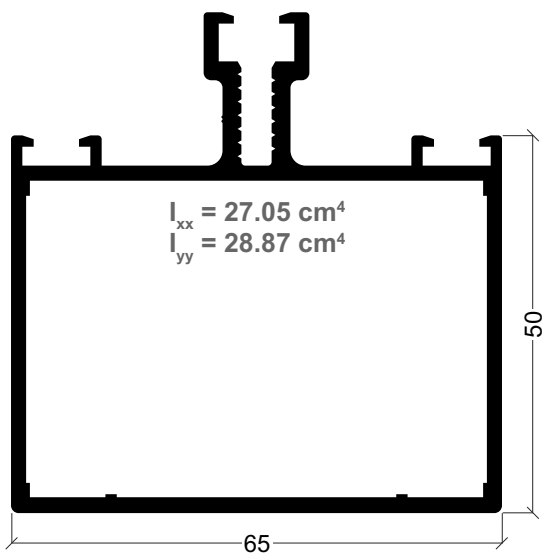

**FL-42**  
Travessa

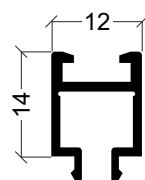

**FL-32**  
Suplemento

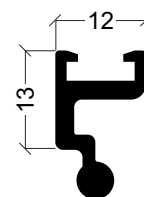

**FL-23**  
Porta vedante regulável

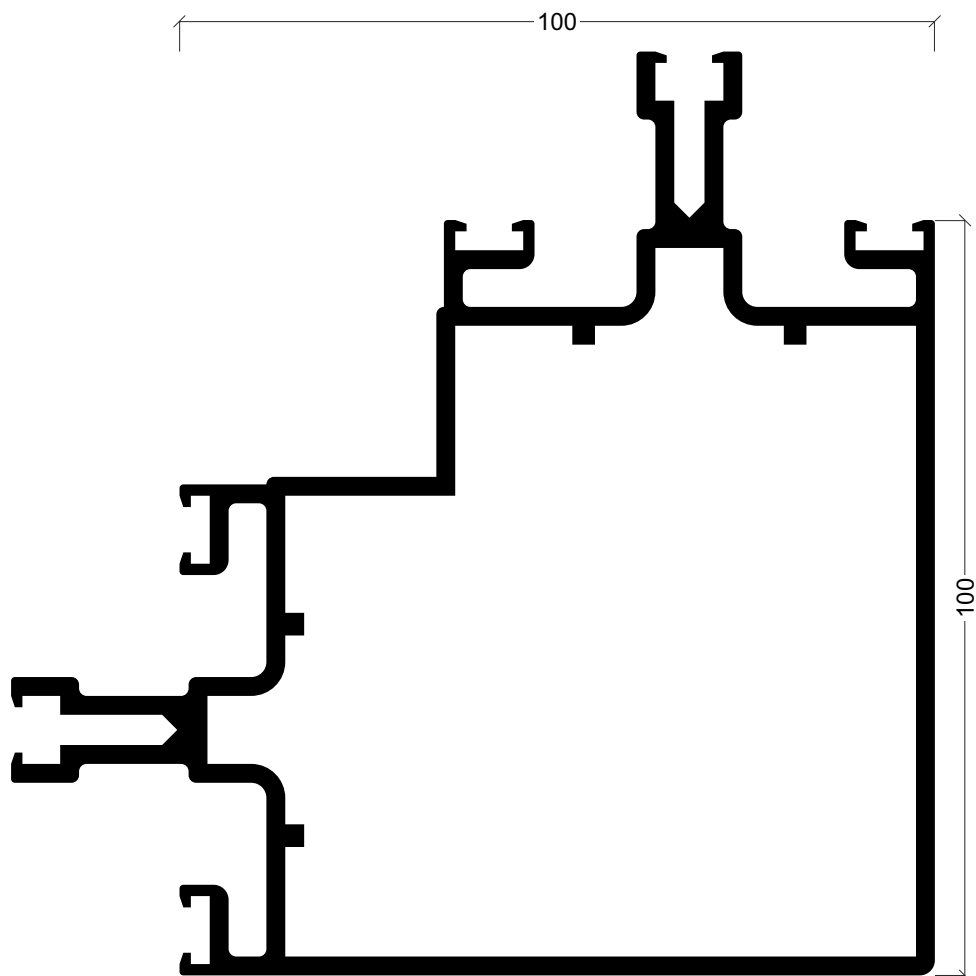

424

**FL-43**  
Esquina 90°

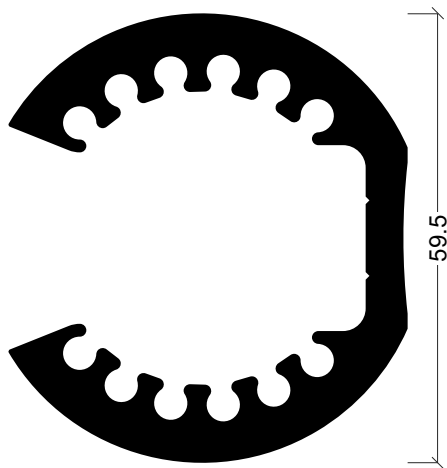

**FL-69**  
Topo de fixação

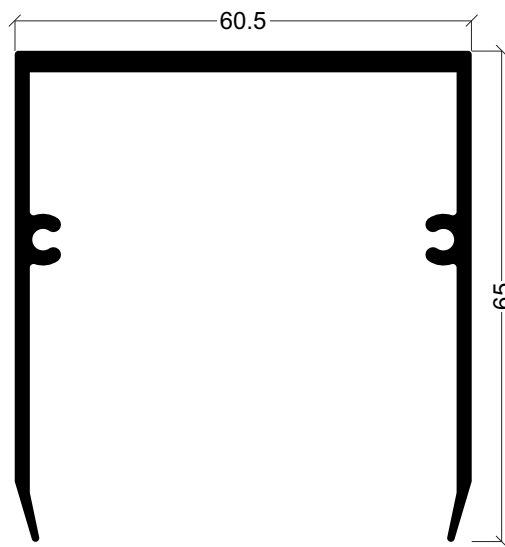

**FL-68**  
Topo de travessa

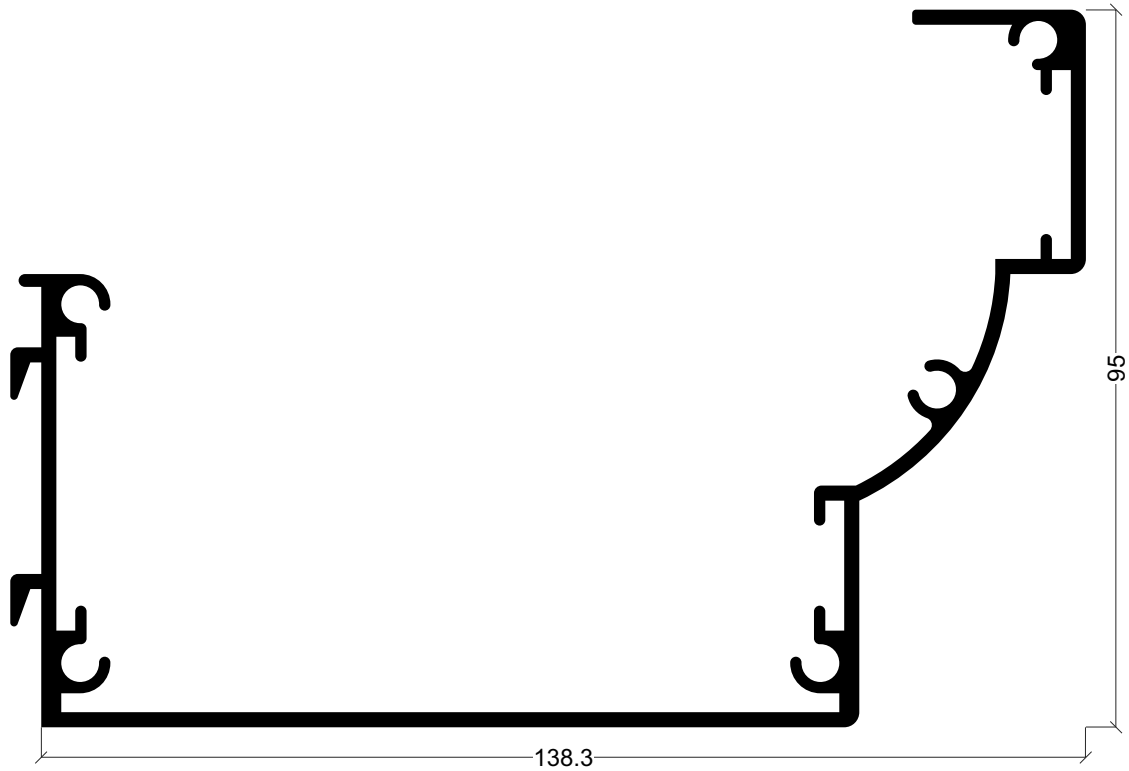

**FL-57**  
Caleira

425

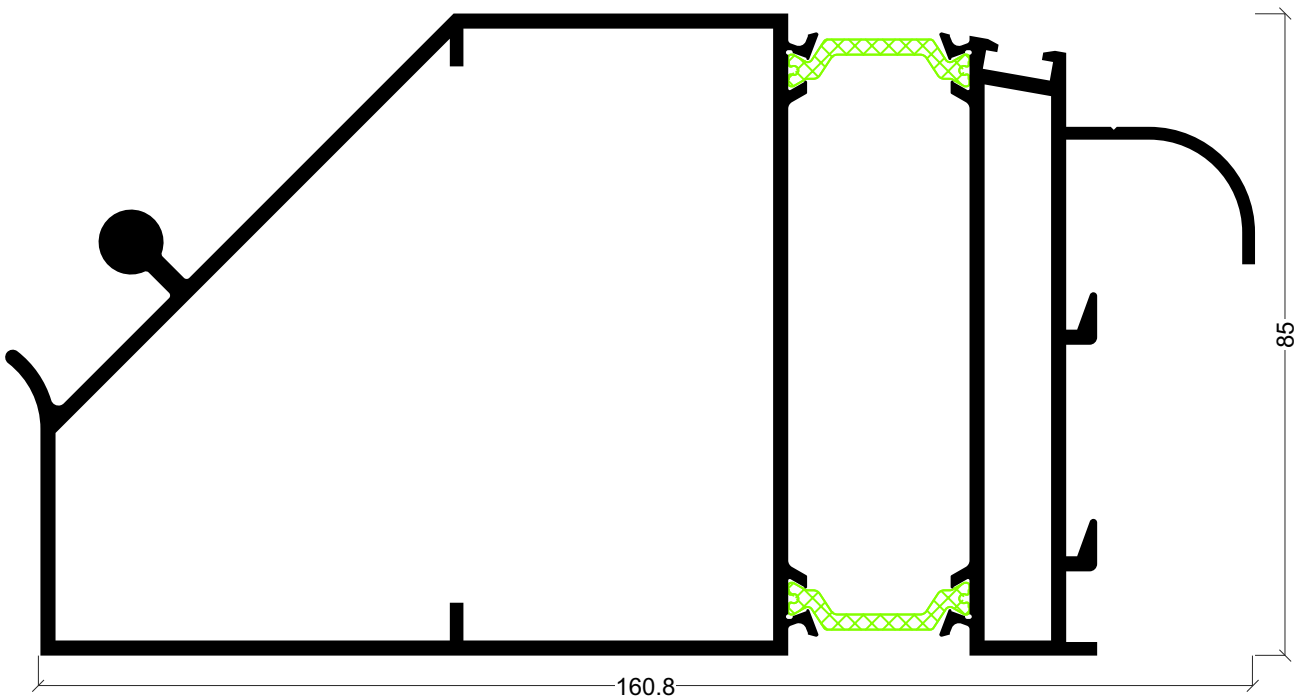

**FL-60**  
Porta basculante inferior

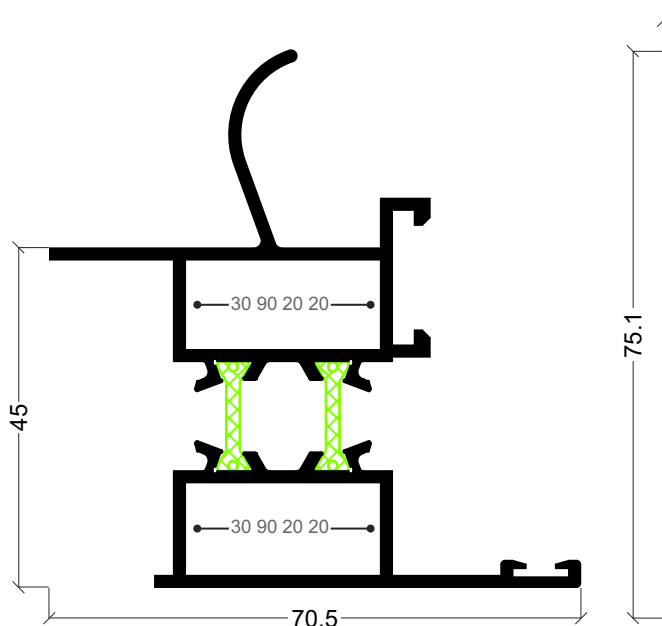

**FL-65**  
Aro fixo claraboia

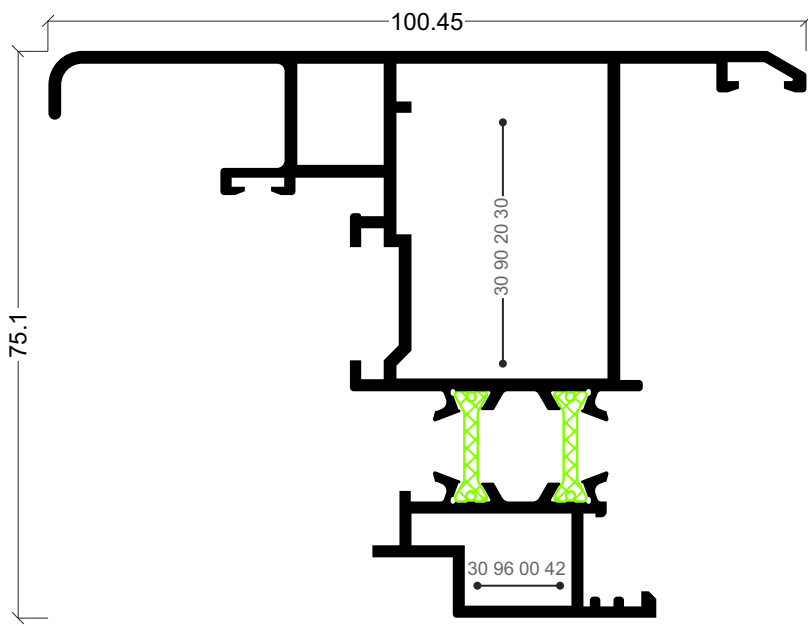

**FL-64**  
Aro móvel claraboia

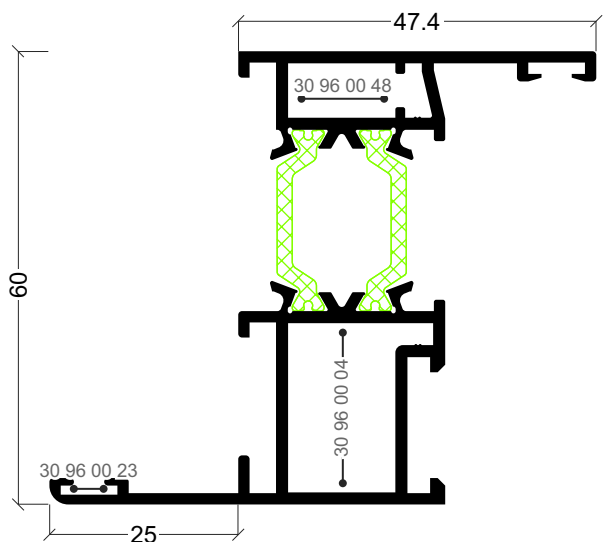

**ARi-35**  
Aro fixo com remate 25 mm

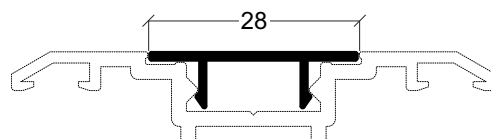

**FL-66**  
Tampa

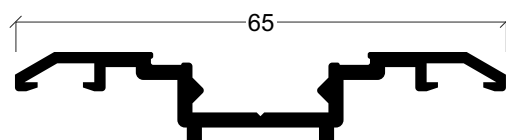

**FL-44**  
Contra tampa

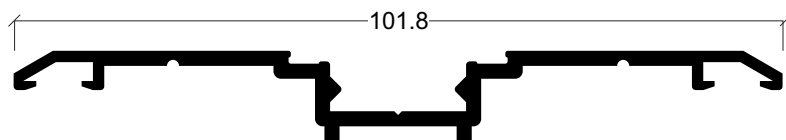

**FL-59**  
Contra tampa (quinar em bruto)

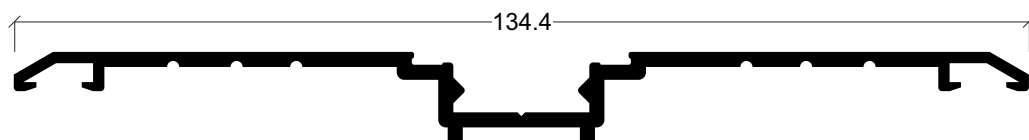

**FL-67**  
Contra tampa (quinar em bruto)



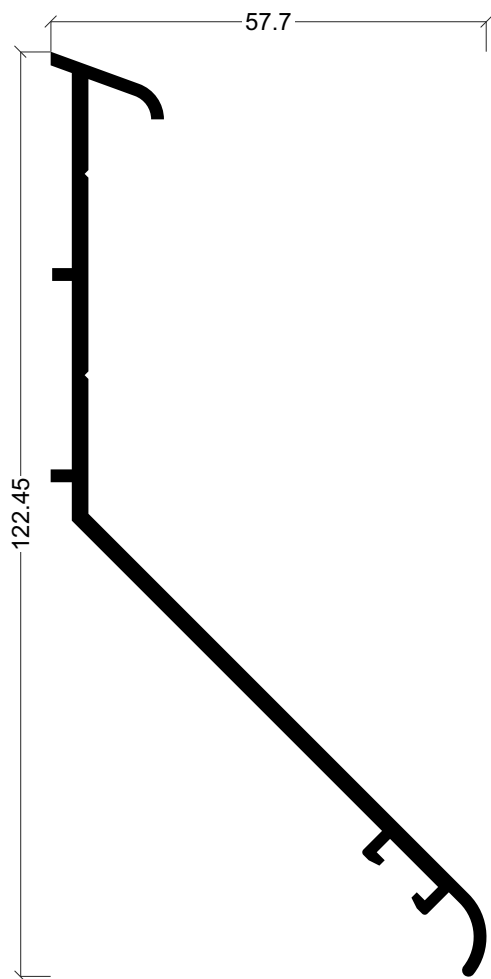

**FL-63**  
Pingadeira superior

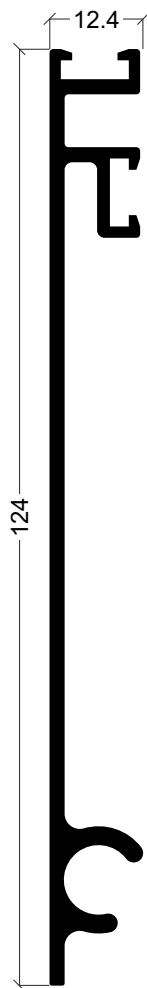

**FL-62**  
Suporte montante basculante

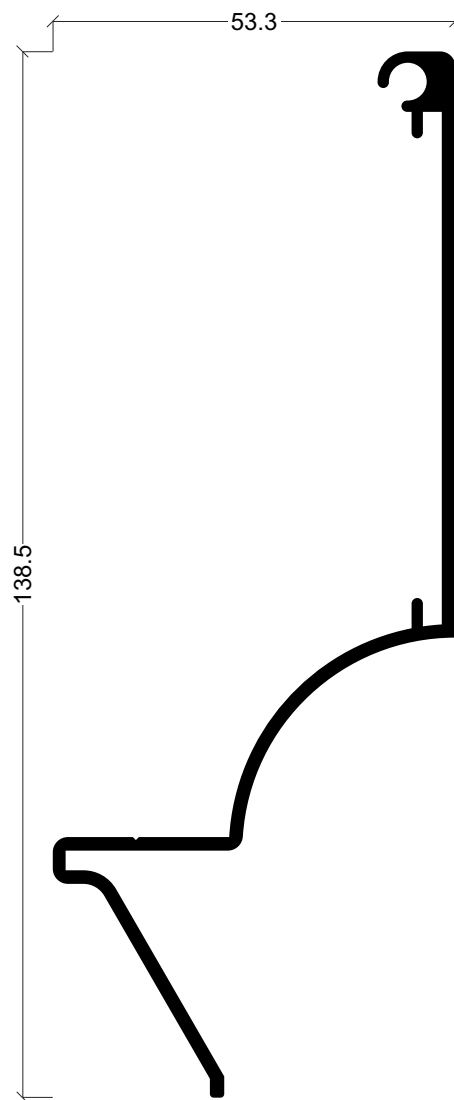

**FL-58**  
Suplemento caleira

427

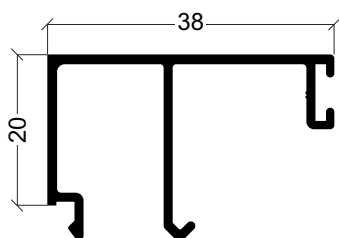

**AX-32**  
Bite

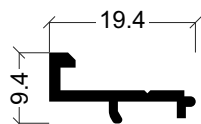

**ARi-29**  
Apoio bite

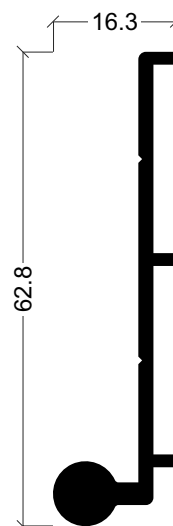

**FL-61**  
Porta basculante superior

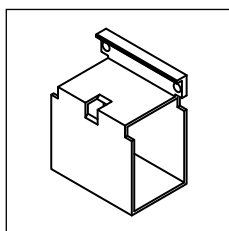

**30 00 90 66**

Topo travessas

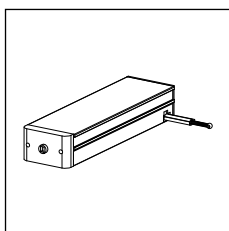

**30 00 95 75**

Motor abertura exterior  
(60 kg - L < 1.4 mt)

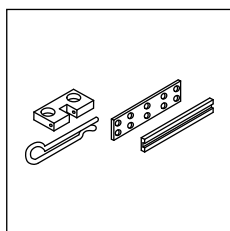

**30 00 95 77**

Conjunto de transmissão  
projectante

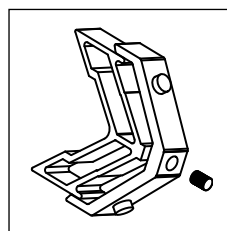

**30 90 20 20**

Esquadro aro fixo  
claraboia

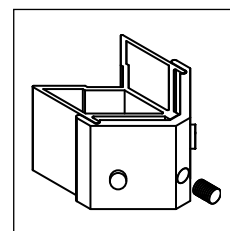

**30 90 20 30**

Esquadro aro móvel  
claraboia

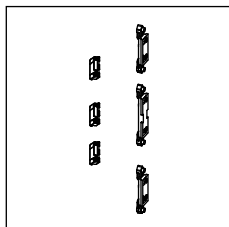

**30 90 20 40**

Transmissão abertura  
claraboia

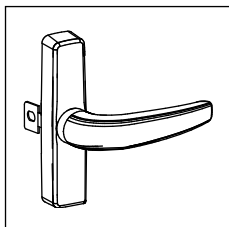

**30 90 20 50**

Puxador claraboia

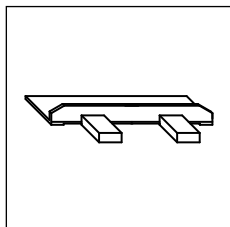

**30 90 20 60**

Remate tapa juntas

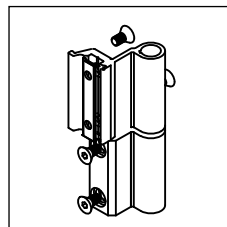

**30 92 00 20/21**

Dobradiça C.E. branco/  
preto

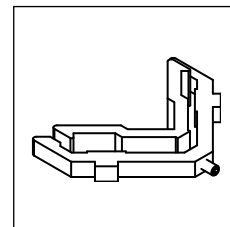

**30 96 00 42**

Esquadro para FL-64

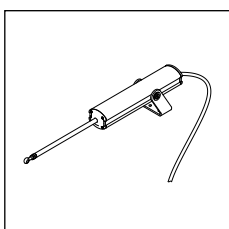

**31 15 10 84**

Motor eléctrico pistão  
(80 kg - L < 1.5 mt)

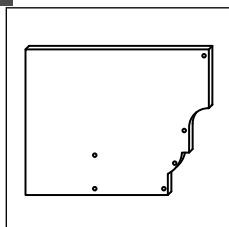

**31 90 20 10**

Topo para careira em  
alumínio

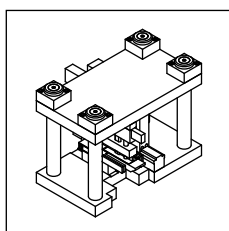

**33 23 19 99**

Cunho XP

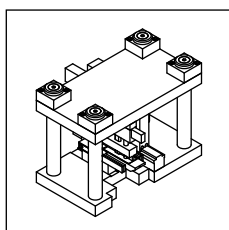

**33 96 87 99**

Cunho esquadro interior  
e exterior ARi/AKi

Referência	Desenho	Descrição
30 00 95 01	11 11	Junta interior montante Junta central montante e travessa
30 00 95 03		Junta central (montante e travessa)
30 00 95 05	5	Junta interior de travessa
30 00 95 06	7	Junta central montante e travessa
30 00 95 07	13	Junta central montante e travessa
30 00 95 08	15	Junta central montante e travessa
30 00 95 10		Junta de estanquidade travessa FL-42
30 00 95 76	9	Junta central montante e travessa
30 90 20 80		Junta exterior sistema ergolux
30 90 20 90		Junta remate superior seccionável
30 93 01 20		Junta para FL-64
30 96 00 18		Junta para FL-65

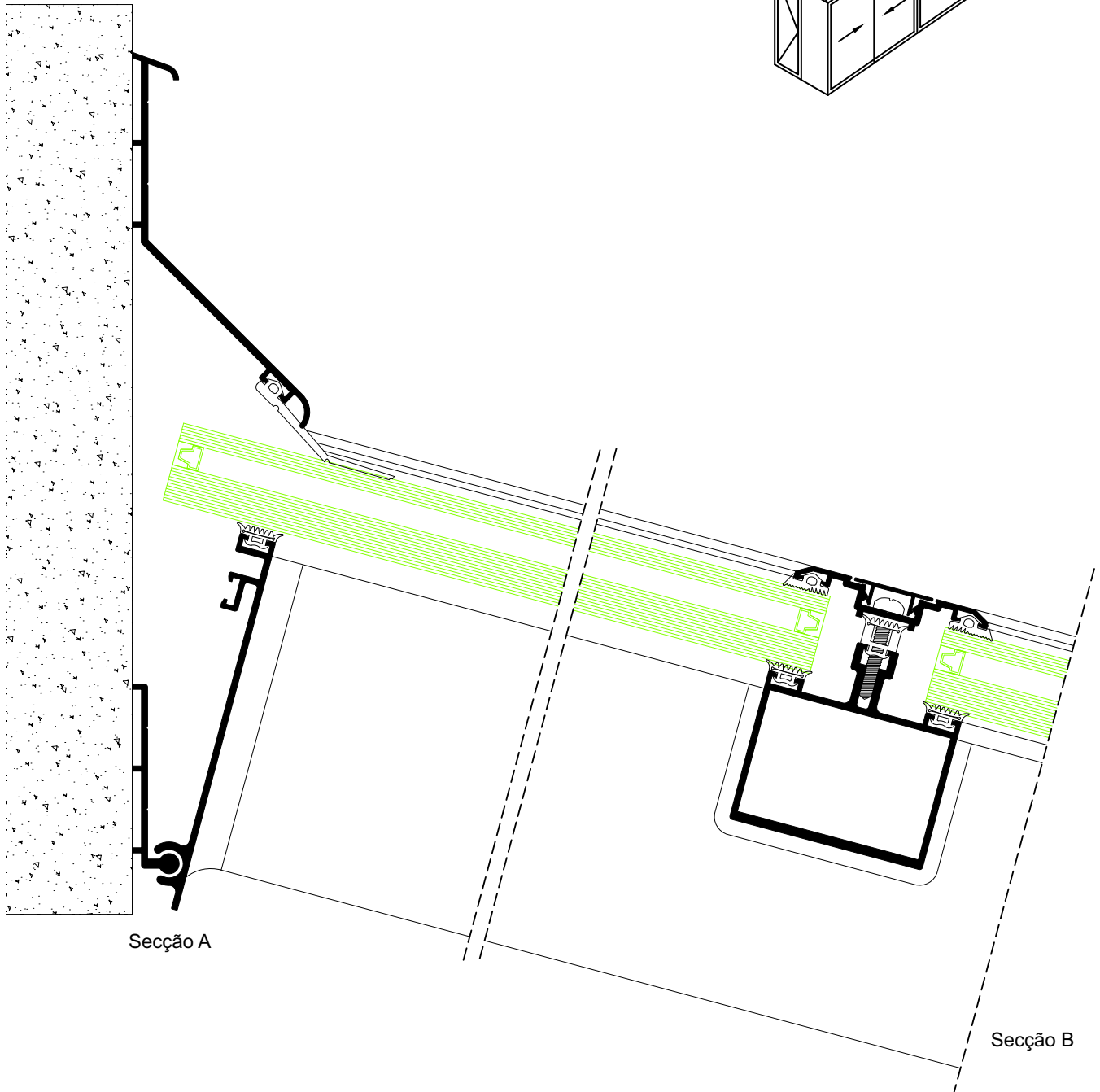
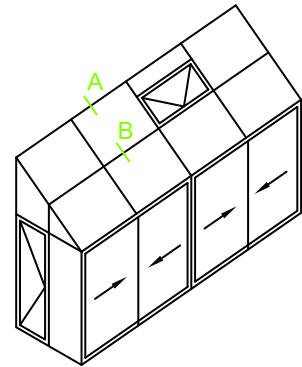

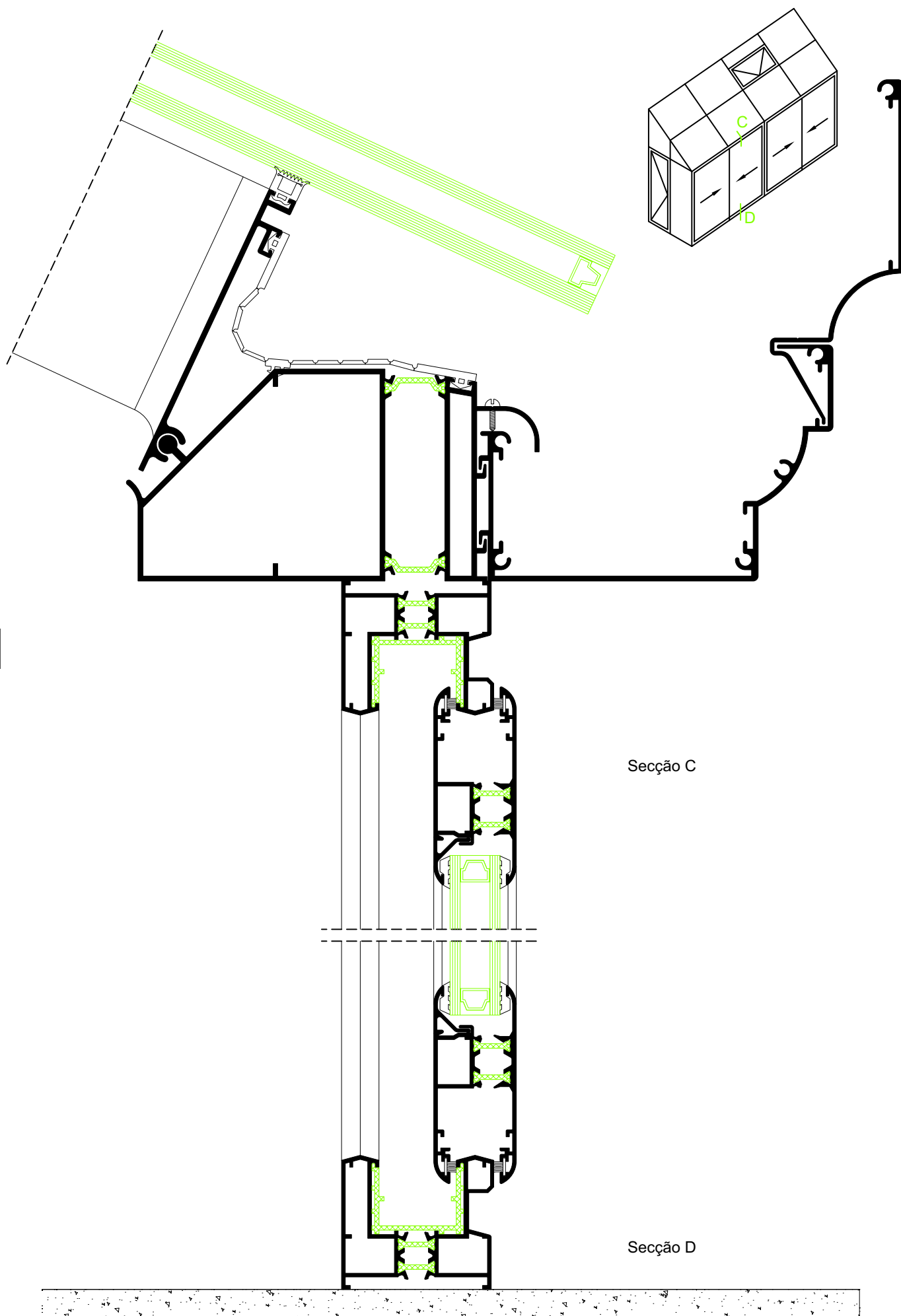

430

Secção C

Secção D

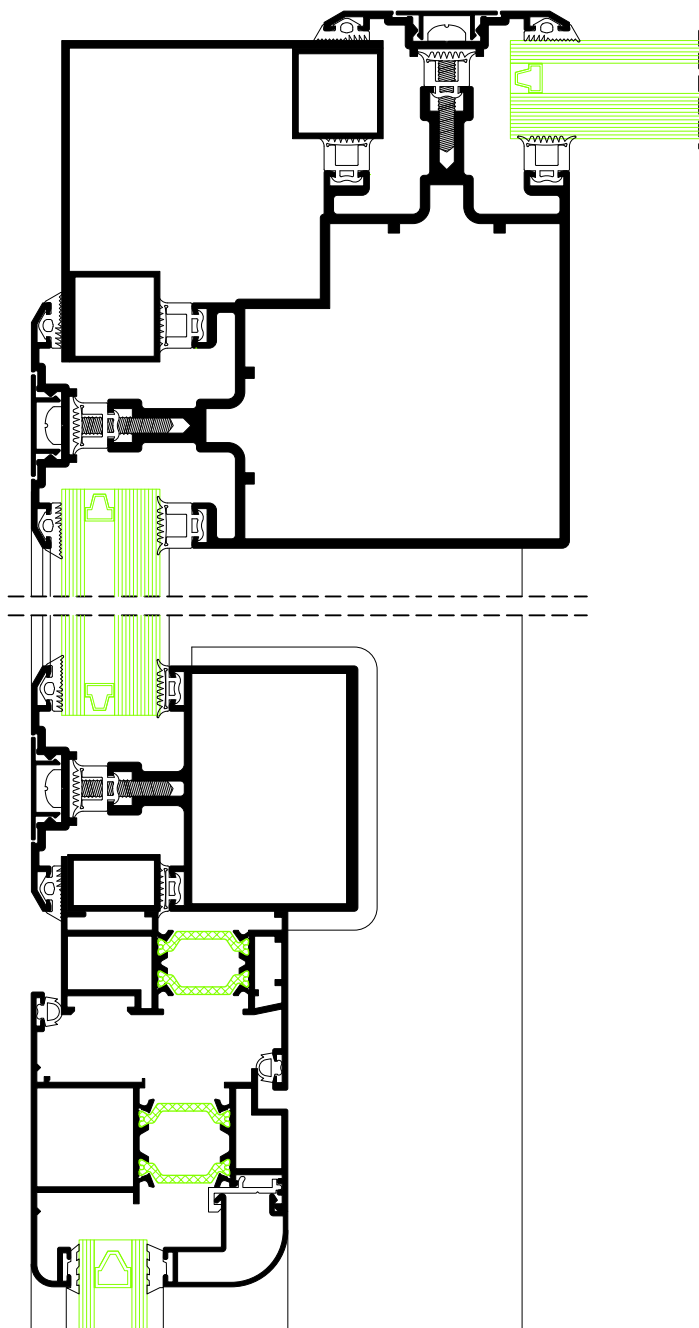

Secção E

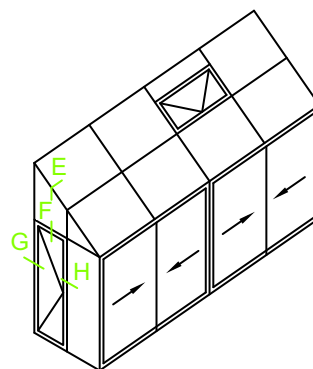

Secção F

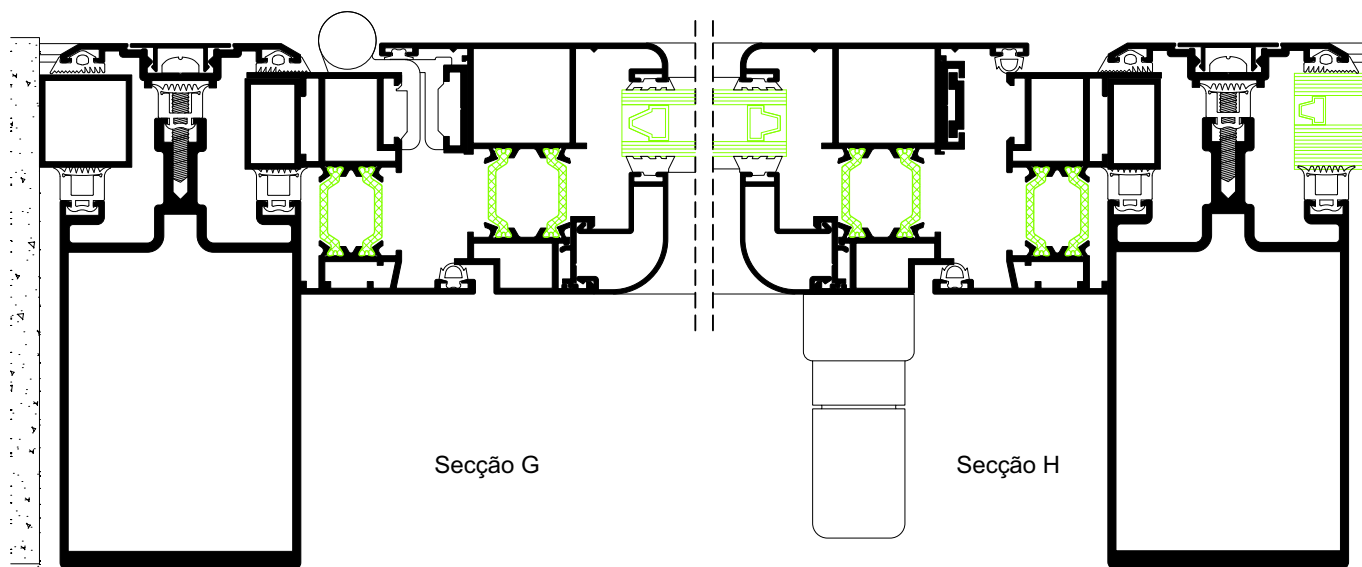

Secção G

Secção H

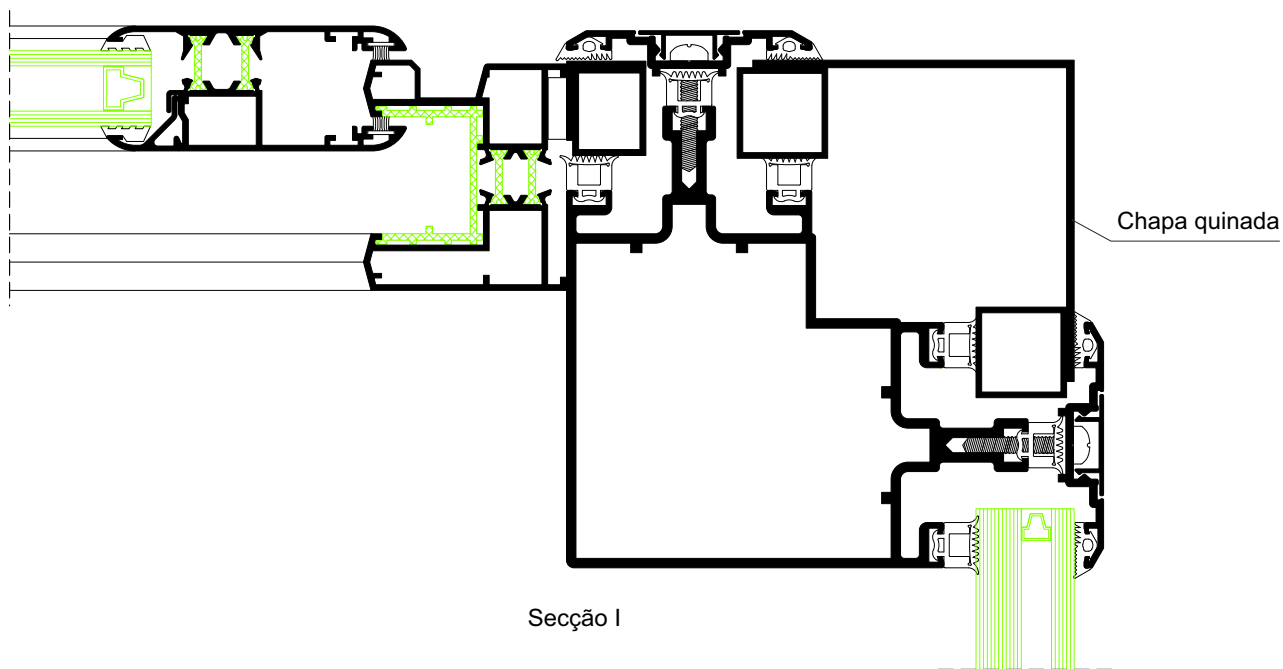
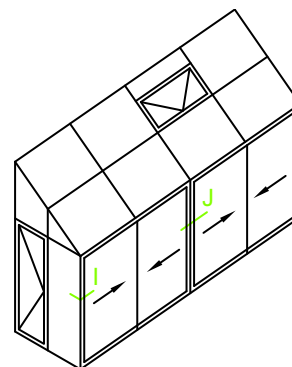

432

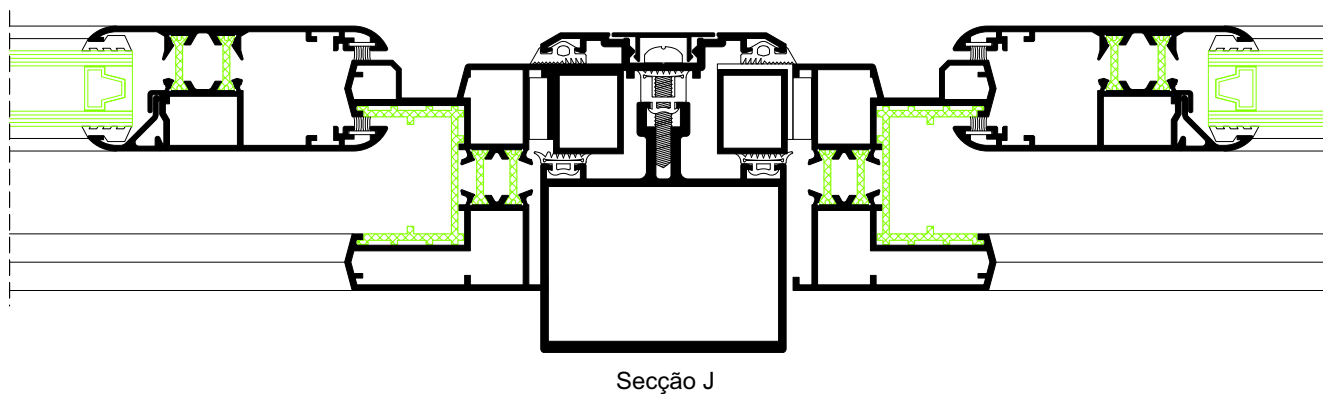

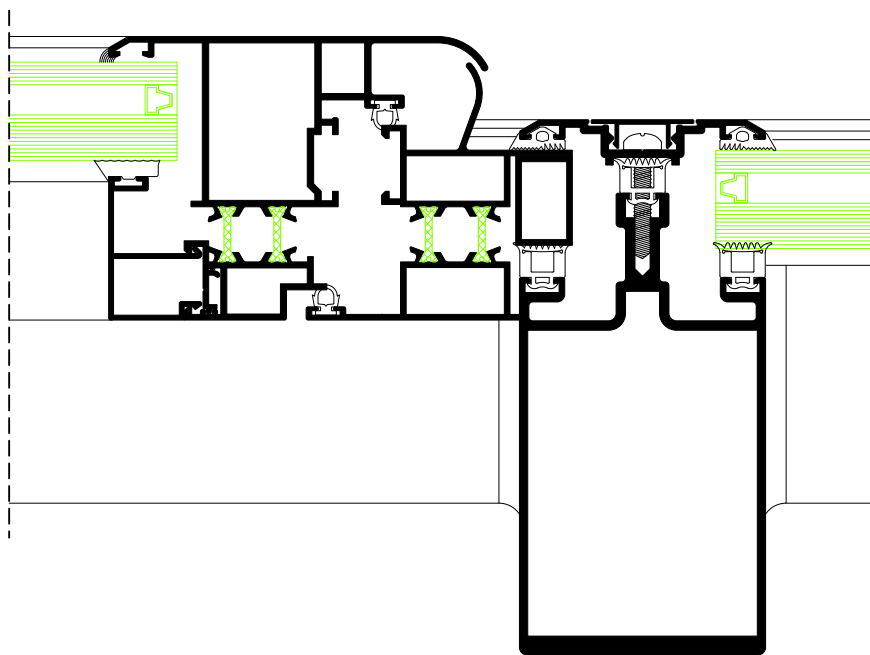
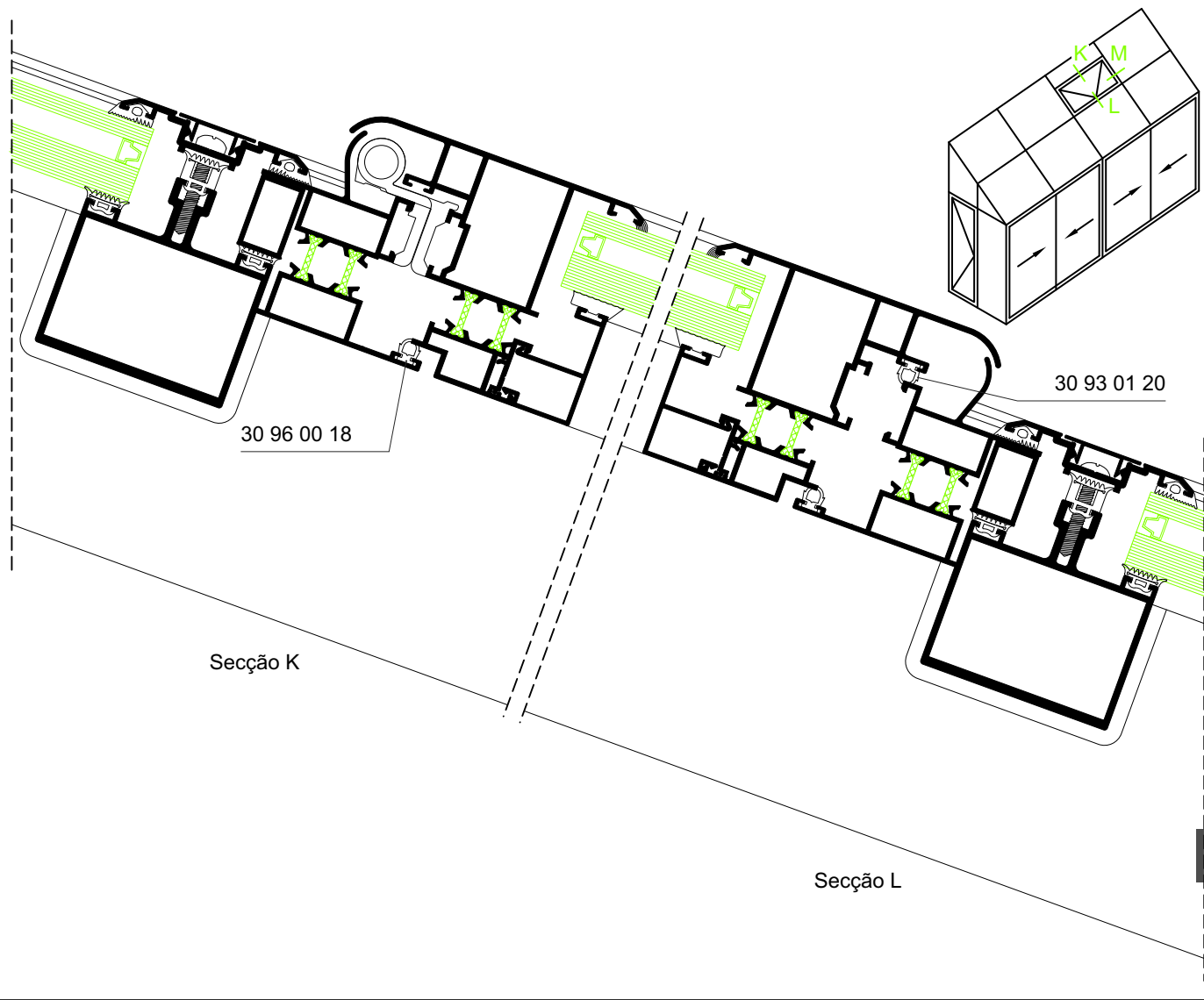

Secção M

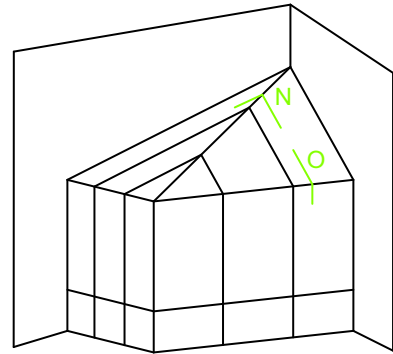

434

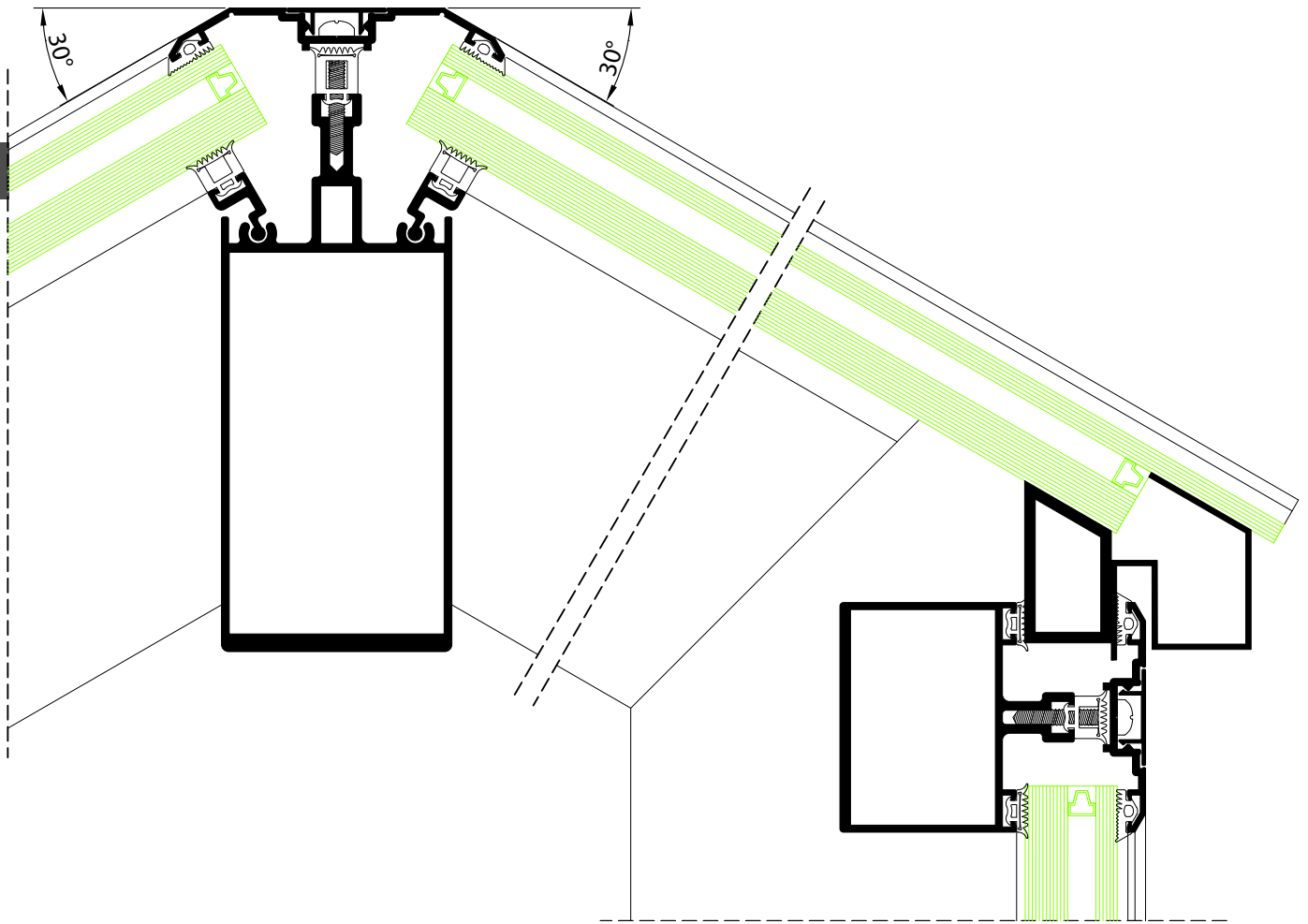

Secção N

Secção O



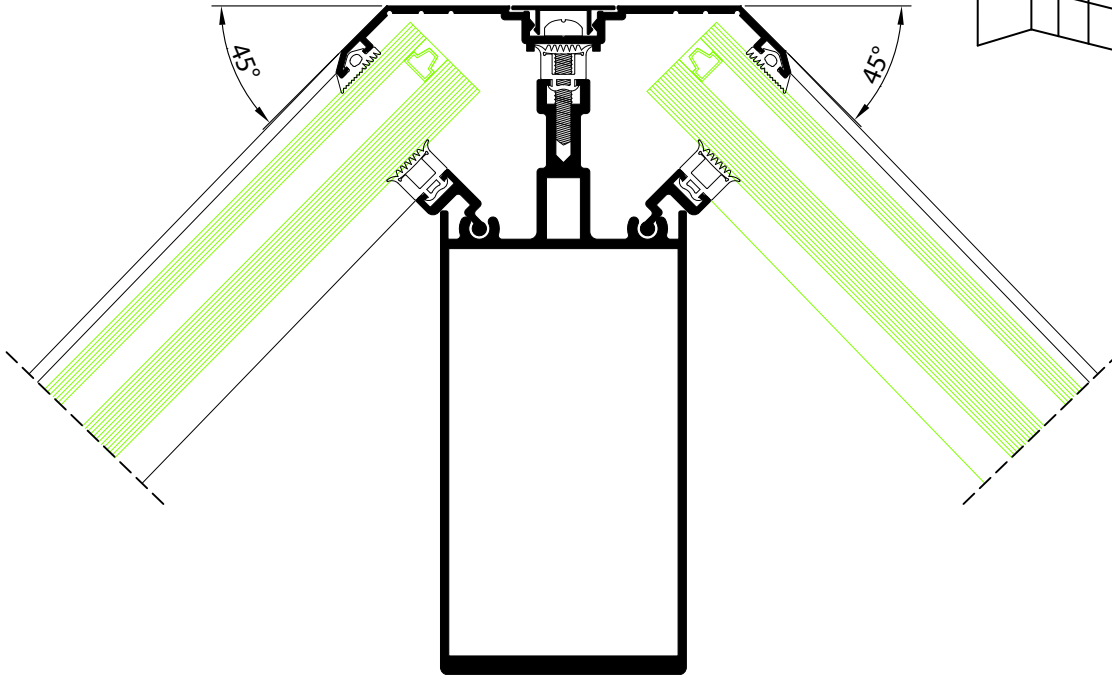
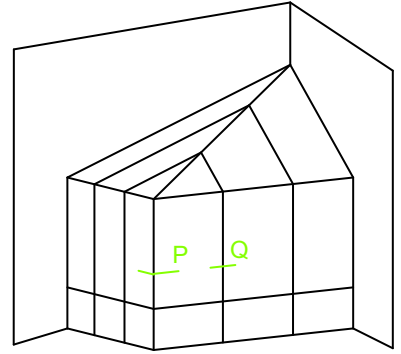

Secção P

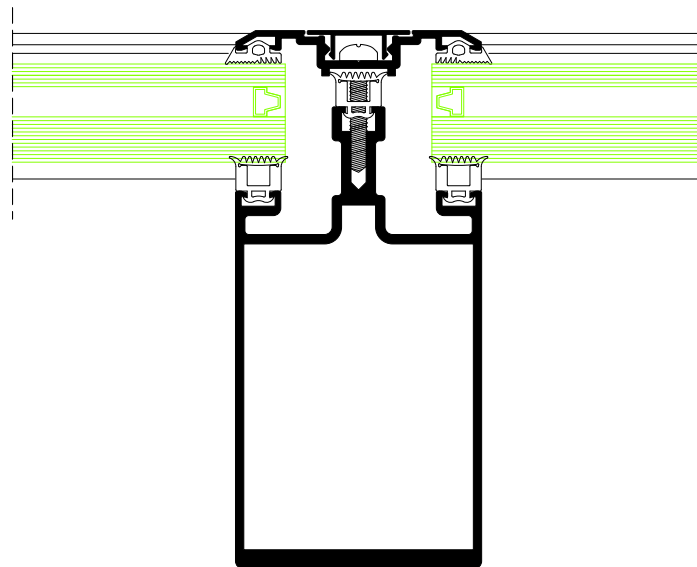

Secção Q

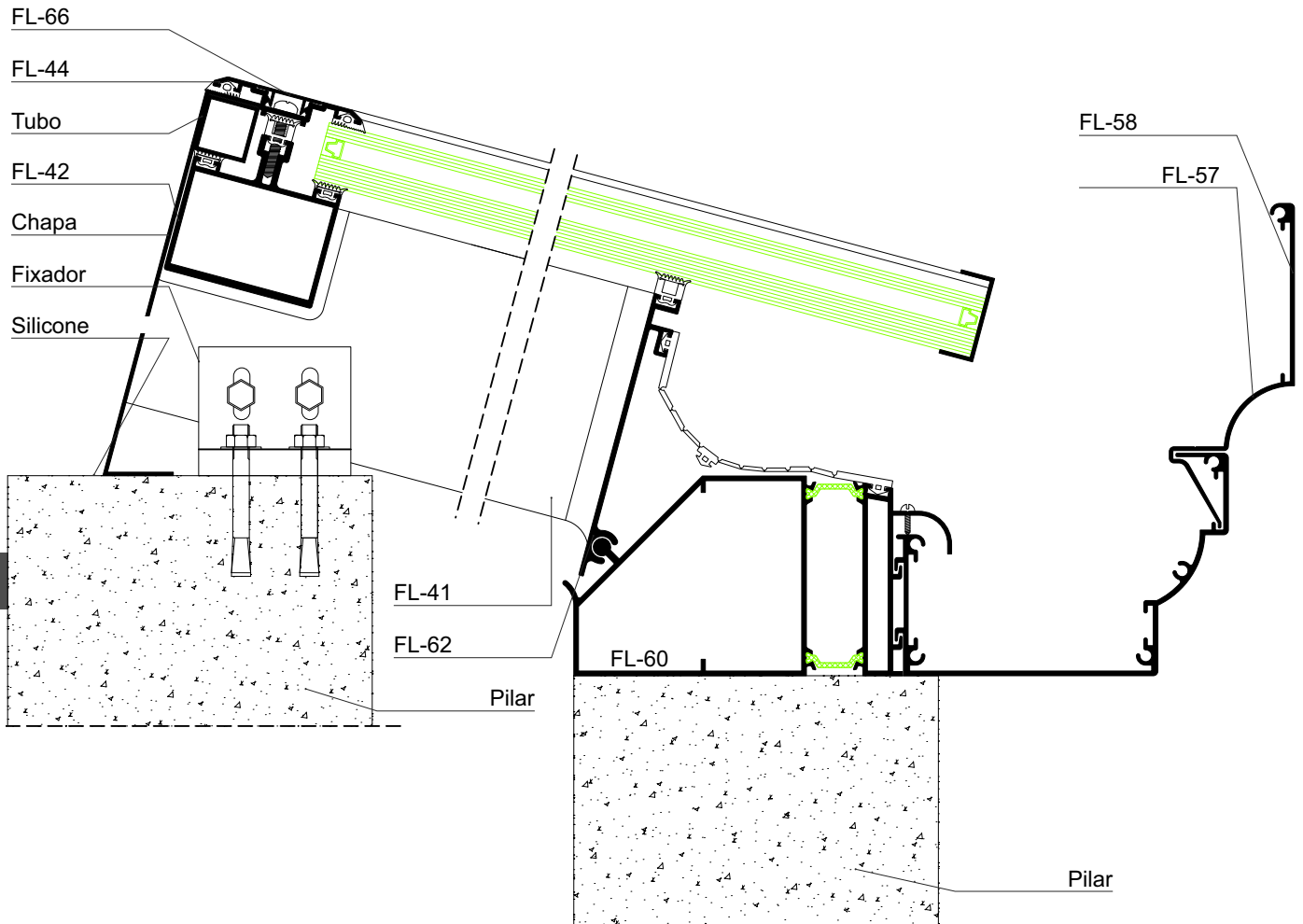

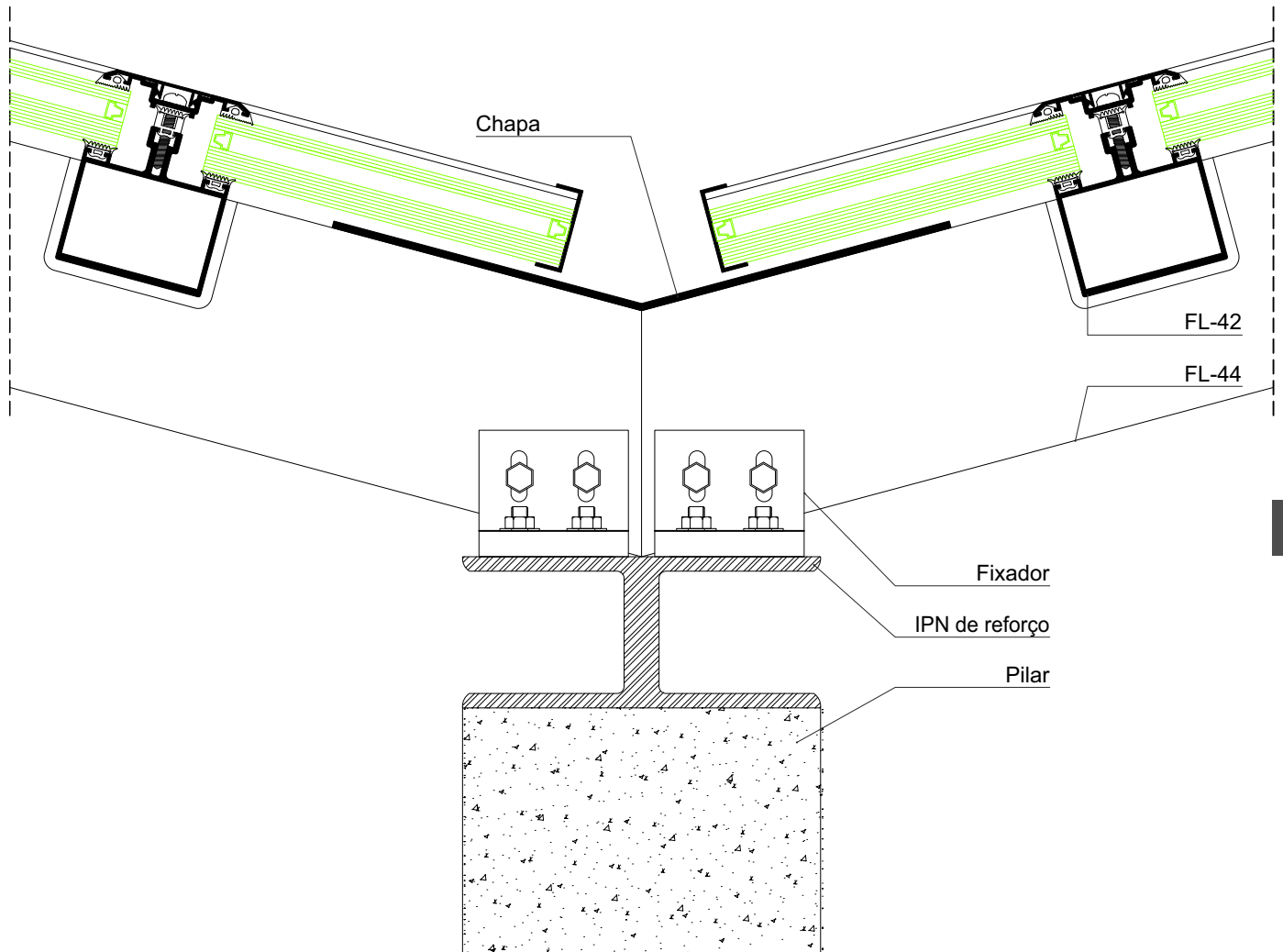

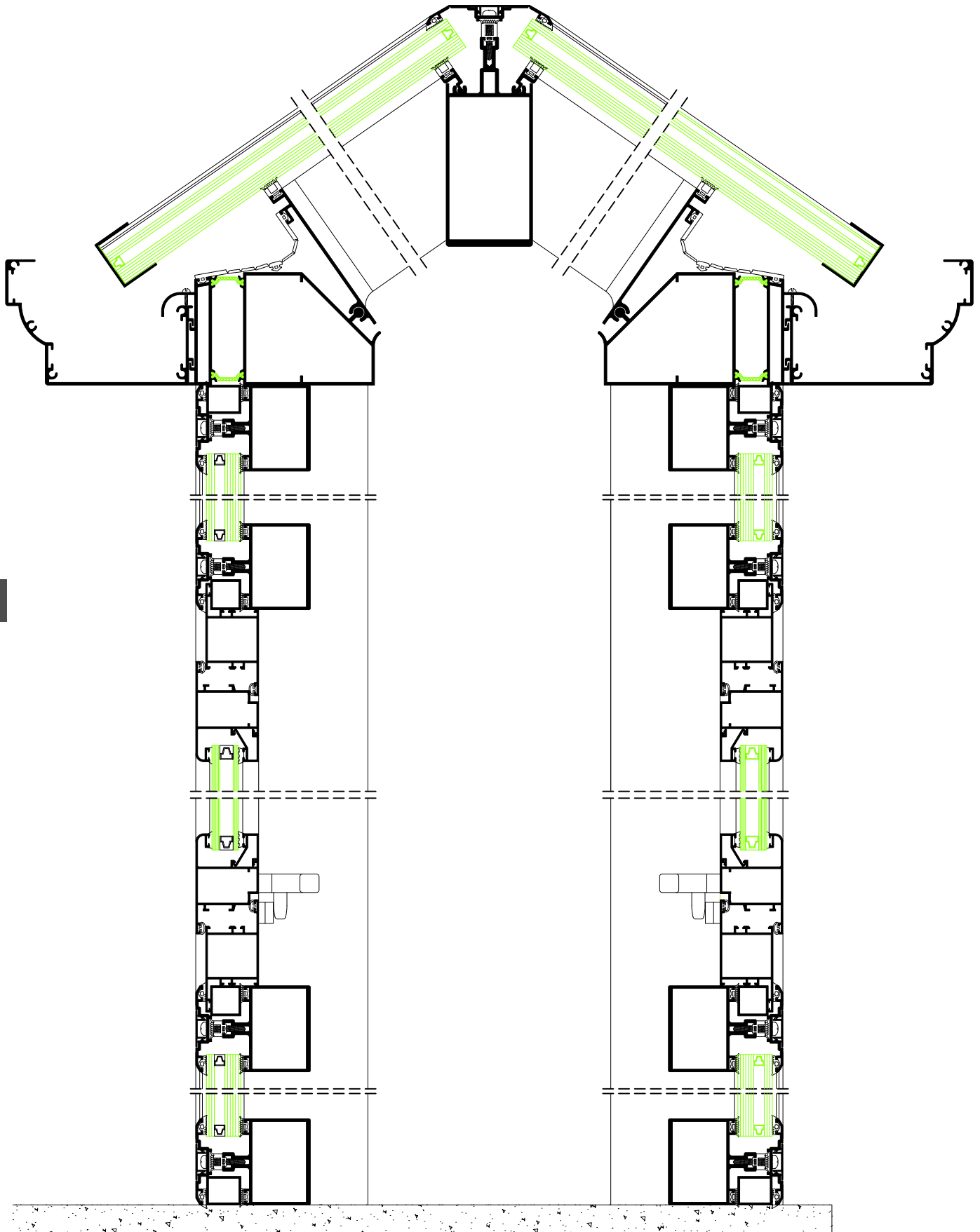

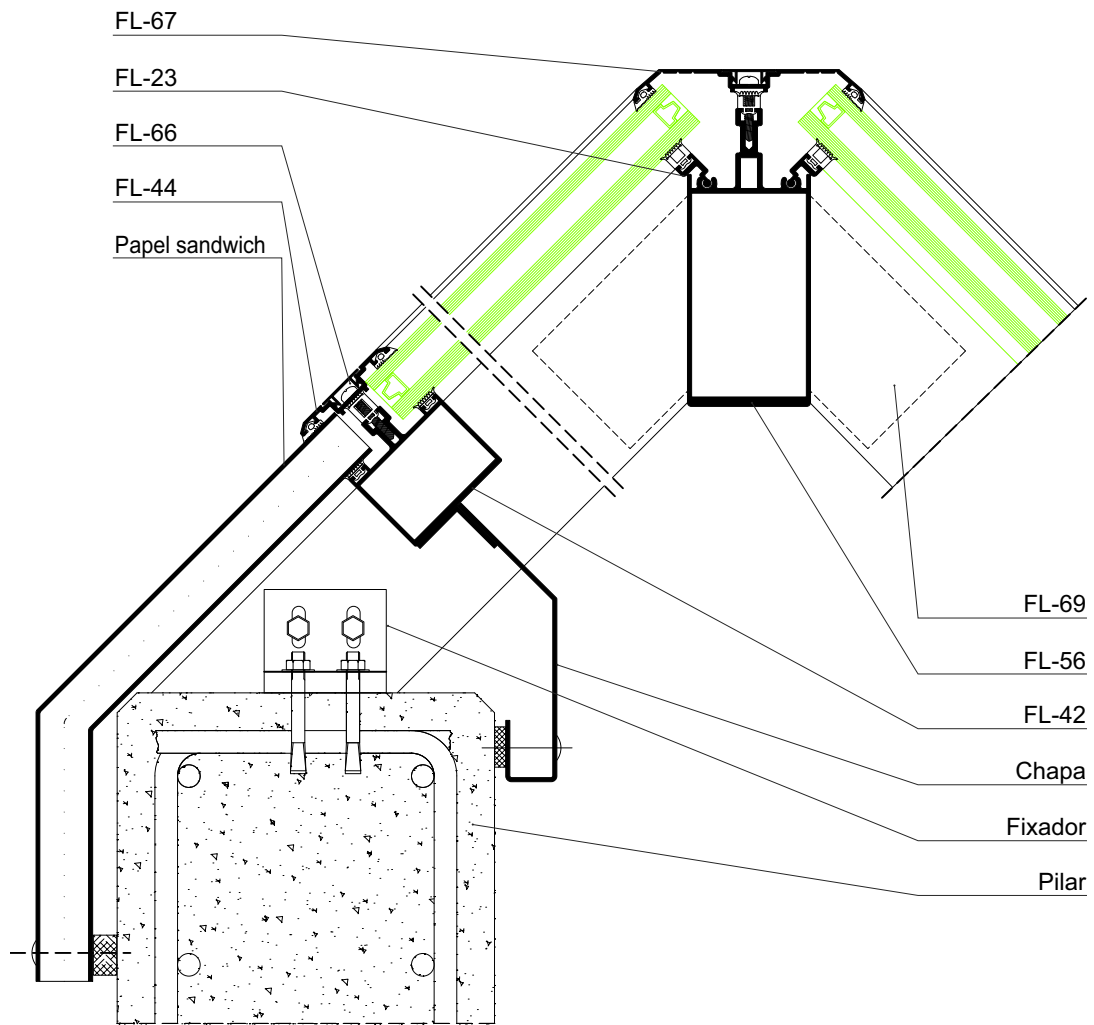

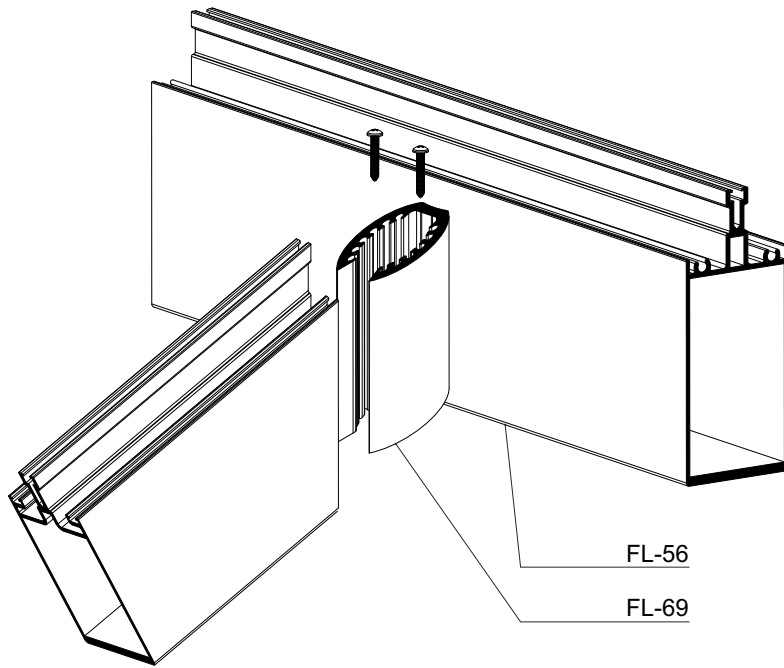

Pormenor I

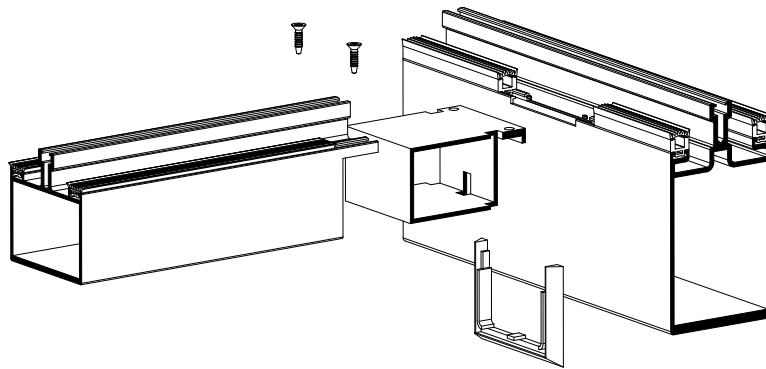

Pormenor II

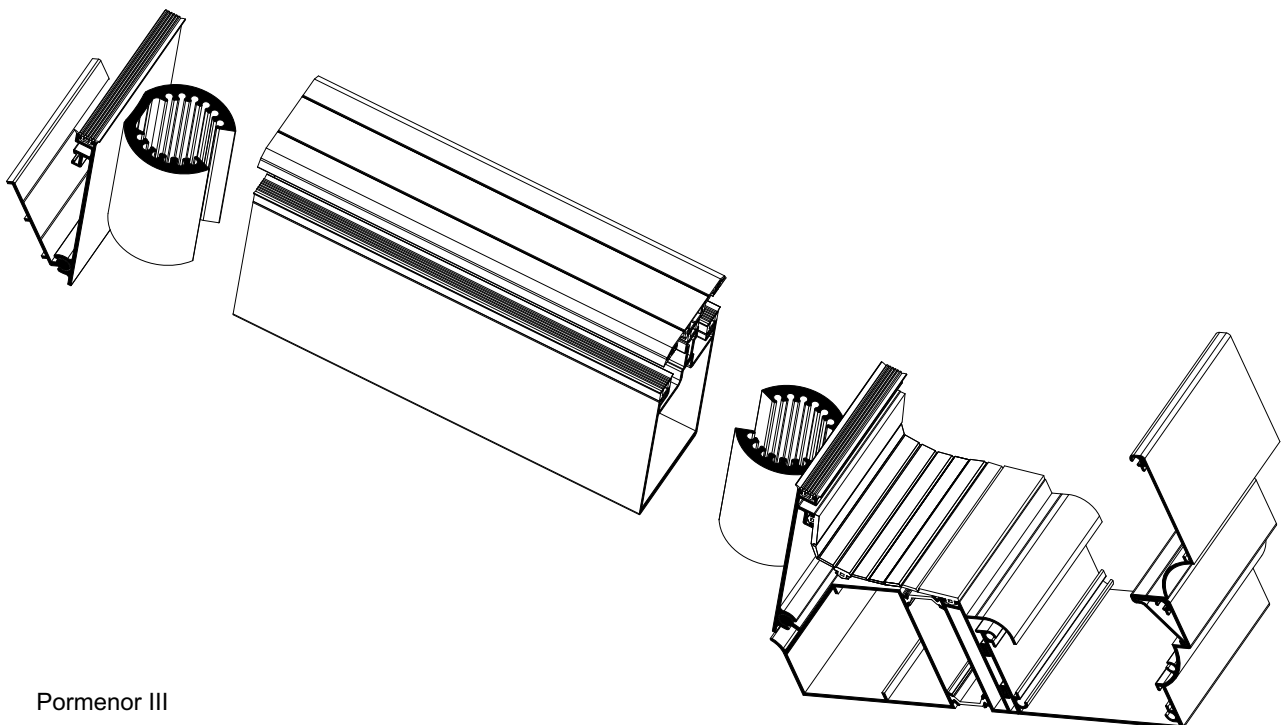

Pormenor III

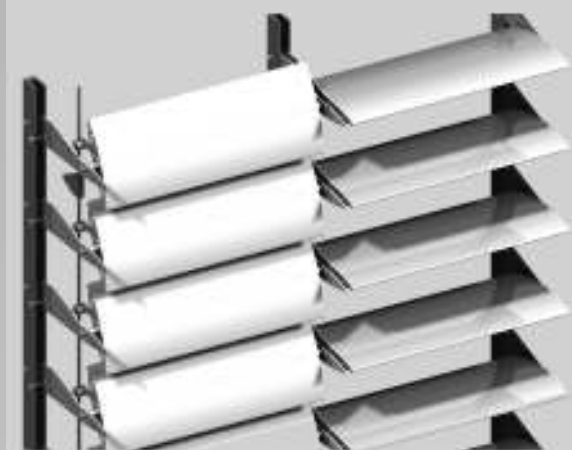

**Lâminas  
Quebra Sol**

## Lâminas Quebra Sol

### Características

Sistemas de alumínio preparados para montagem sobre fachadas que visam fazer o efeito quebra sol apresentando ao mesmo tempo uma forma estética.

Permitem a montagem nas seguintes formas:

- lâminas fixas;
- lâminas móveis.

Os sistemas de lâminas móveis permitem um controle sobre a sua orientação através de um mecanismo manual ou motorizado em que ambos poderão ser comandados à distância. As lâminas quebra sol existem com as secções transversais de 120, 165, 250 e 345 mm com uma espessura média dos perfis de alumínio de 1.5 mm.



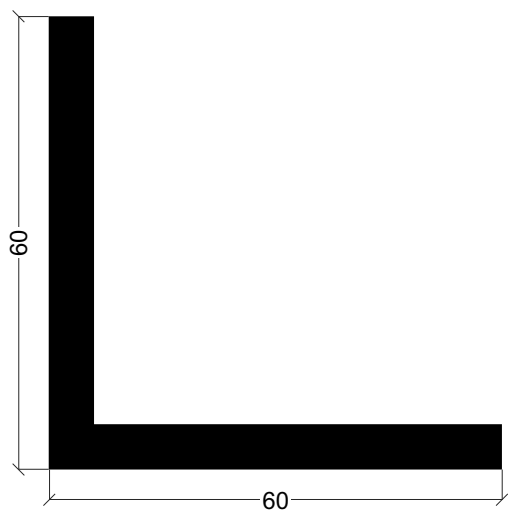

**L-25**



**G-01**

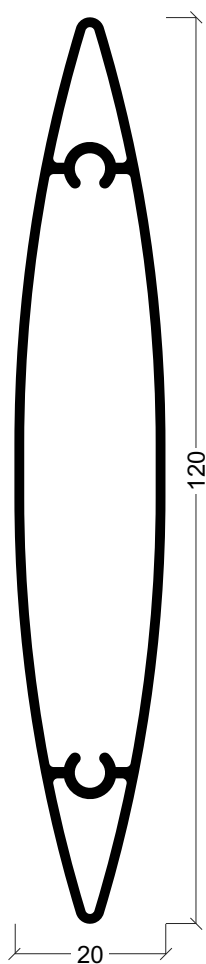

**Z-58**

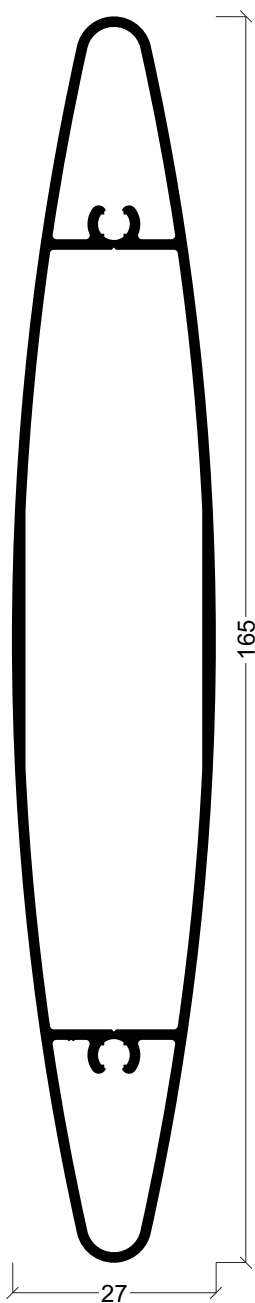

**Z-68**

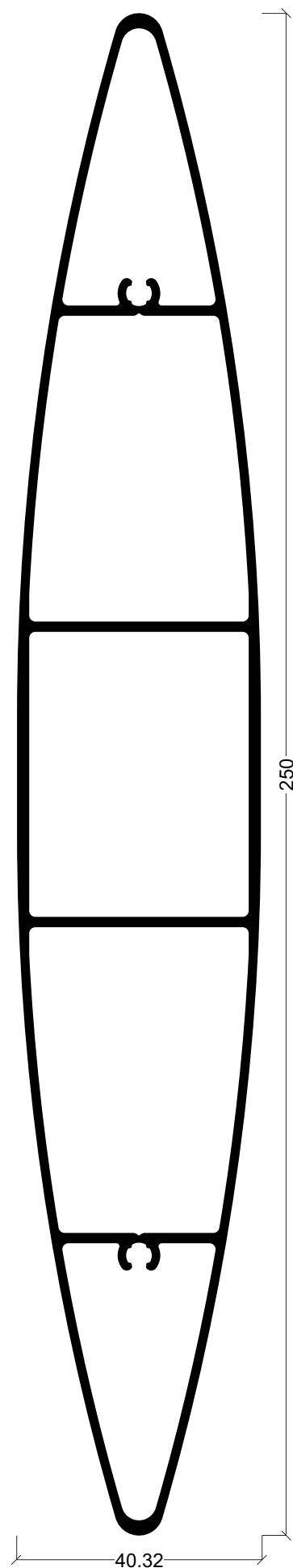

**Z-62**

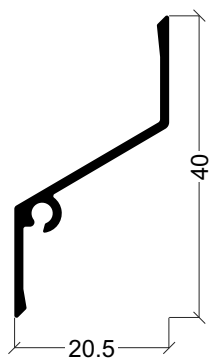

Z-26

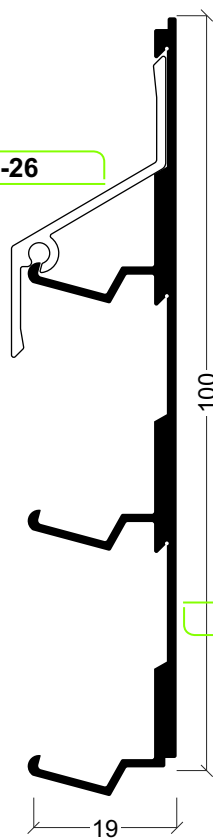

Z-26

Z-25

Z-25 + Z-26

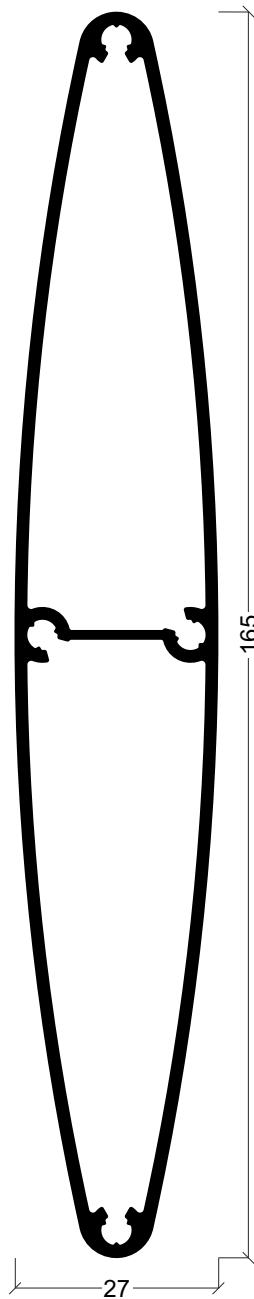

Z-64 (lâmina fixa)

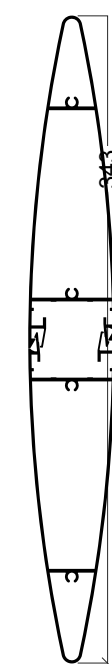

Z-65 + Z-65

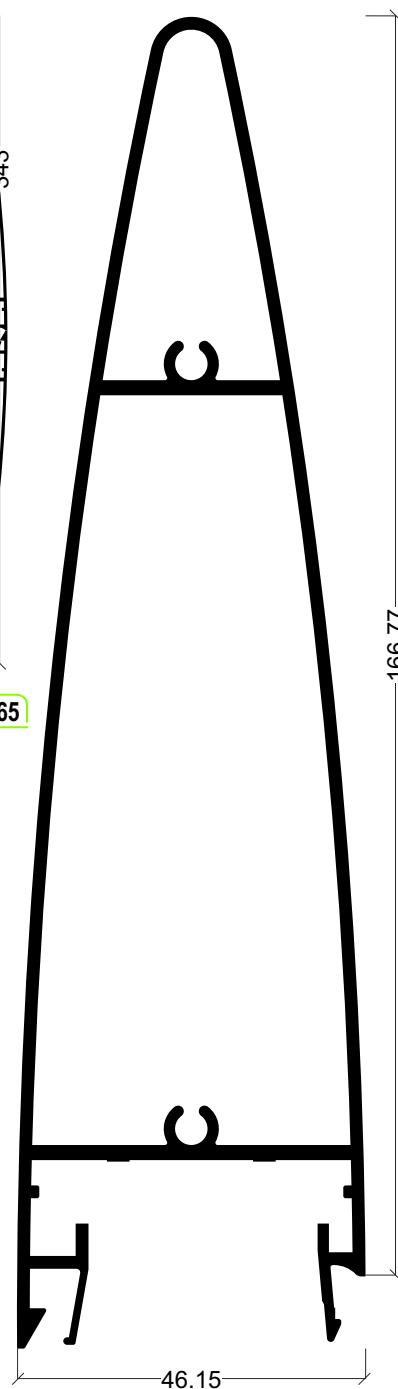

Z-65

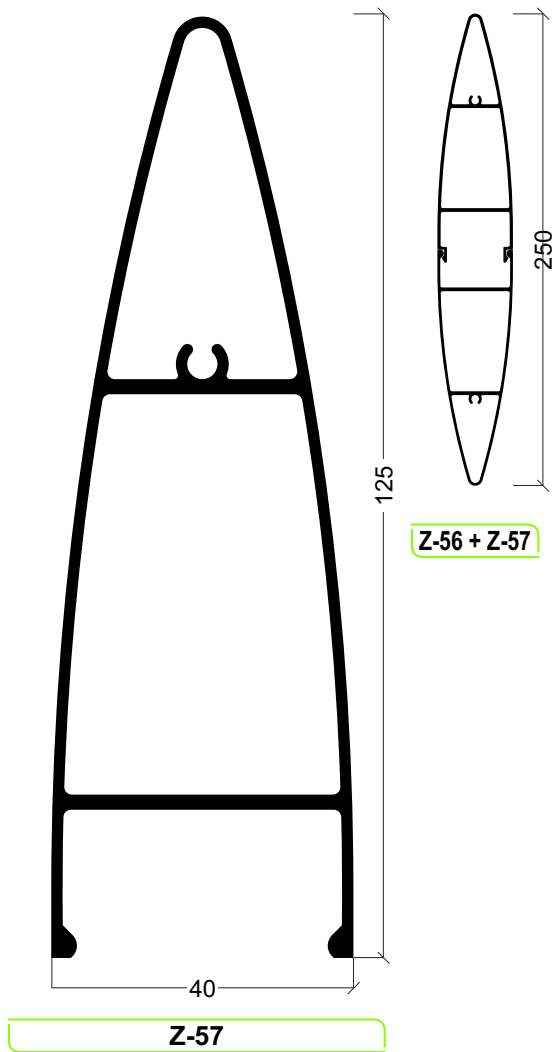

**Z-56 + Z-57**

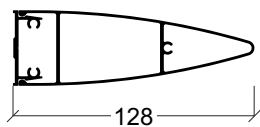
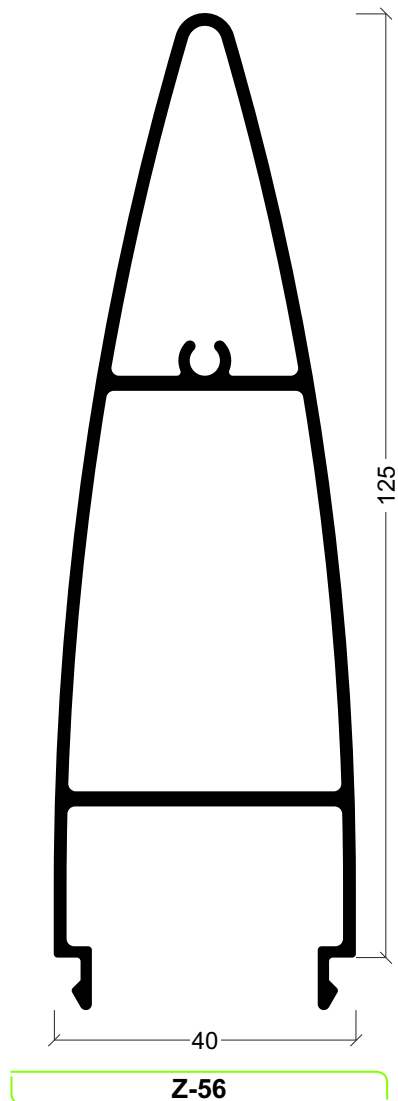

**Z-57 + Z-63**

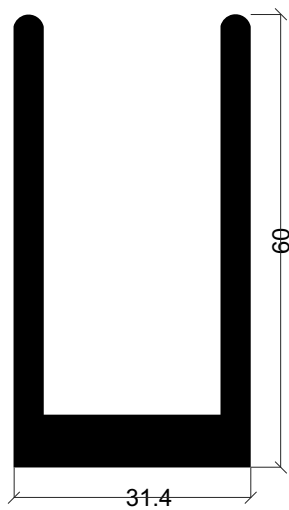

**U-09**

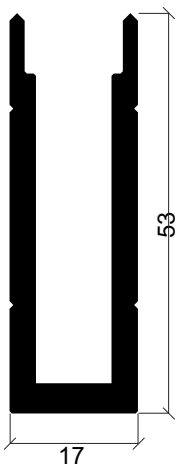

**U-10**

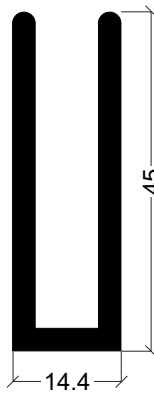

**U-08**

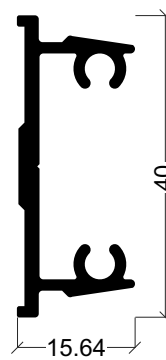

**Z-63**

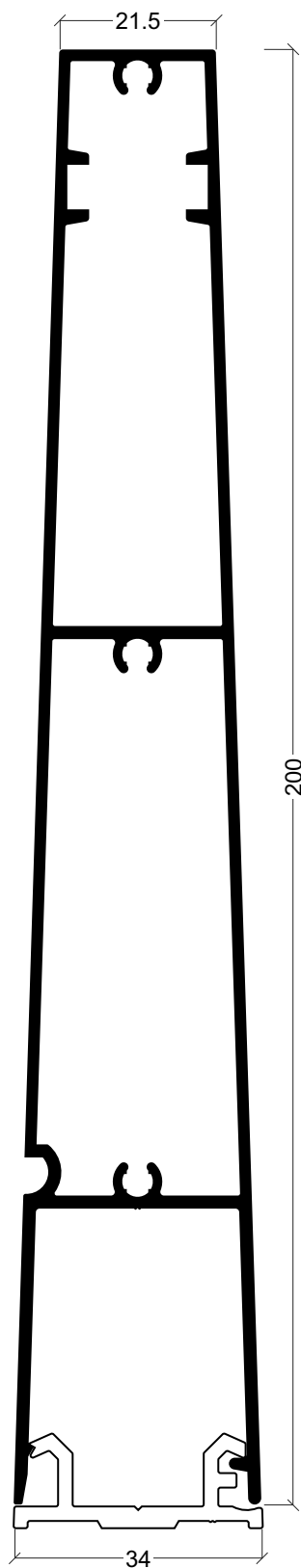

**Z-67**

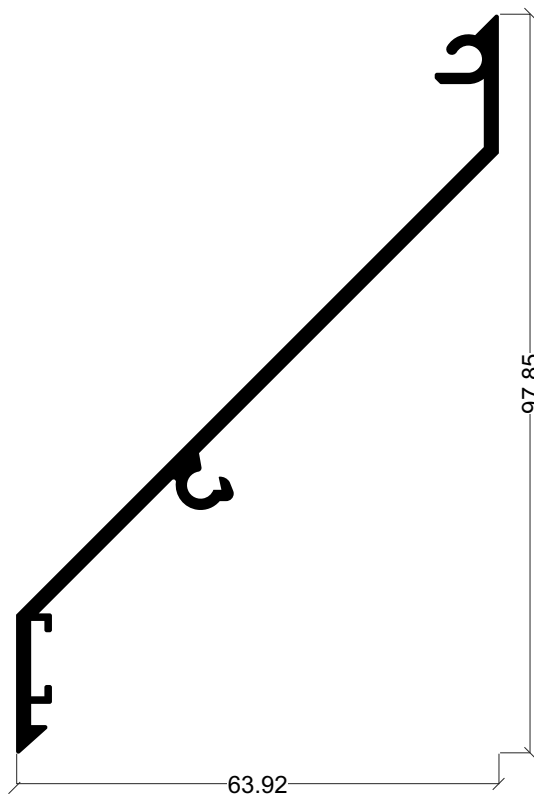

**Z-24**

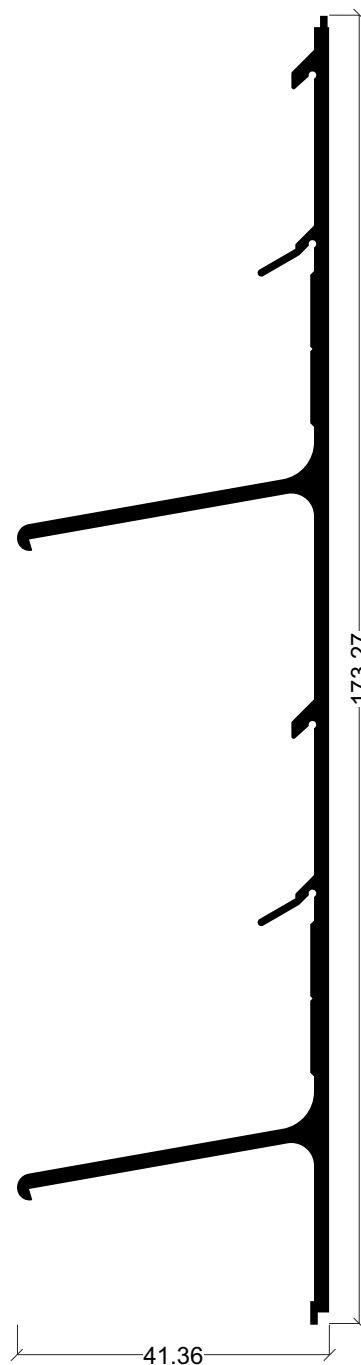

**Z-23**

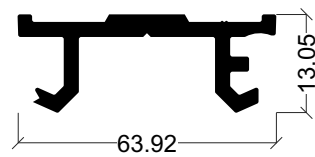

**Z-66**

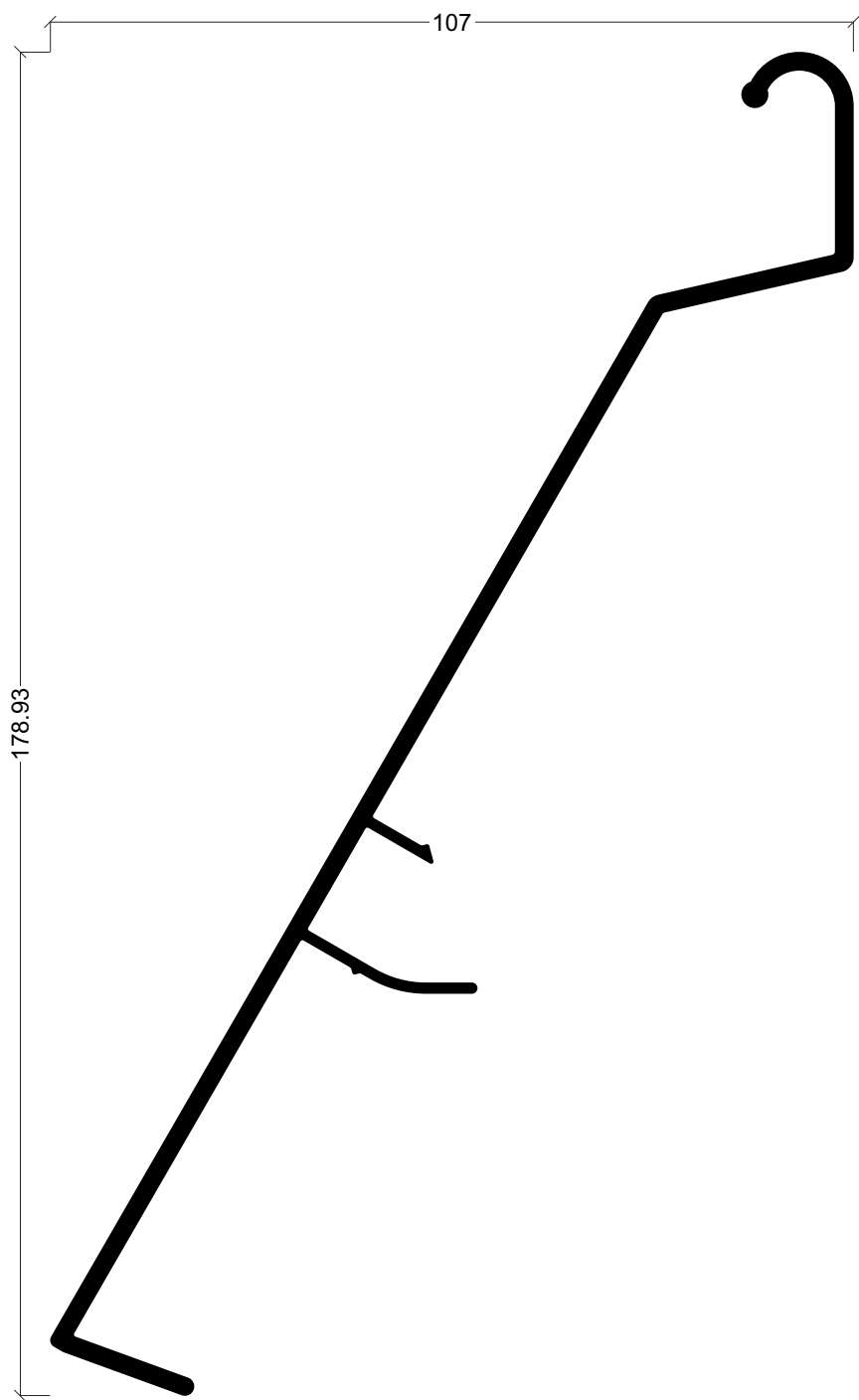

Z-43

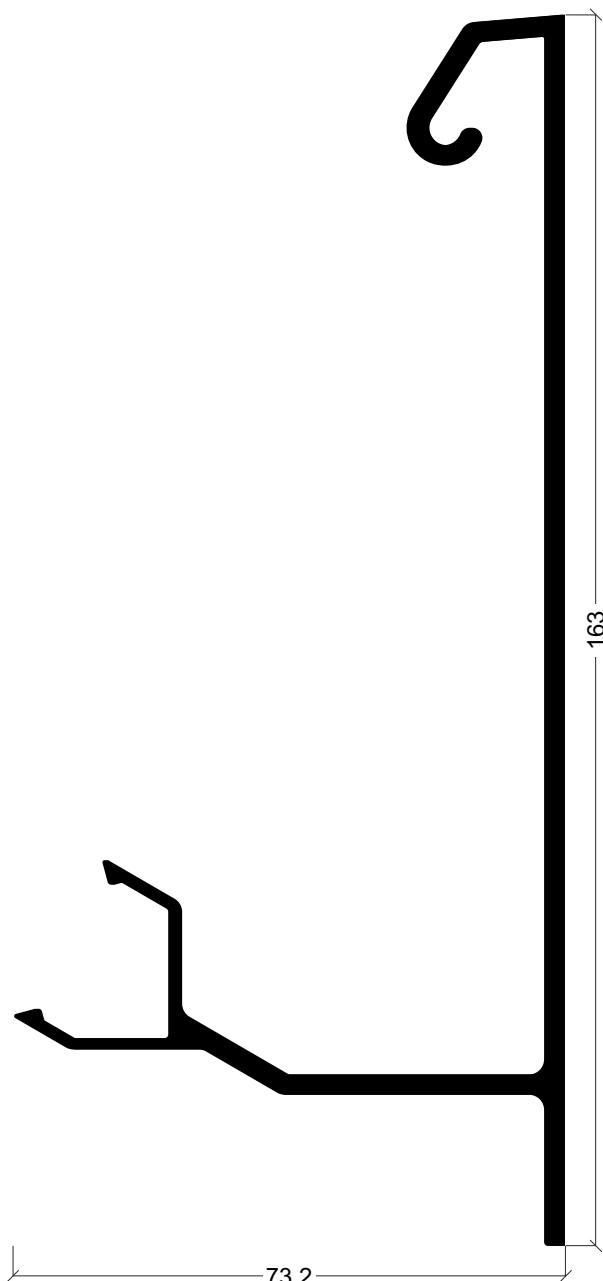

Z-42

447

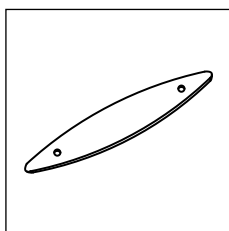

**31 15 00 40**

Topo simples 250 mm

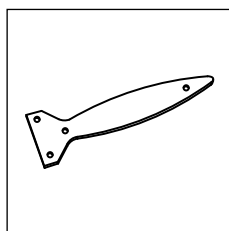

**31 15 00 42**

Topo fixação 120 mm

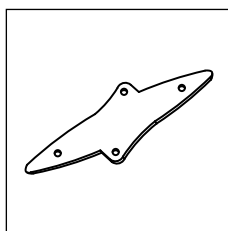

**31 15 00 63**

Topo fixação central  
120 mm

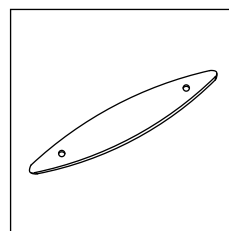

**31 15 00 67**

Topo simples 120 mm

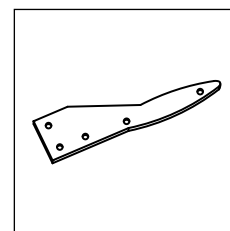

**31 15 00 71**

Topo fixação alongado  
120 mm

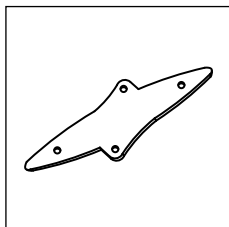

**31 15 00 75**

Topo fixação central  
250 mm

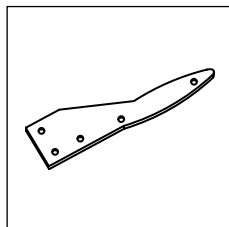

**31 15 00 79**

Topo fixação alongado  
250 mm

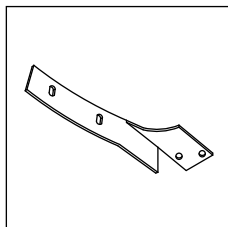

**31 15 00 84**

Suporte central 250 mm  
direito

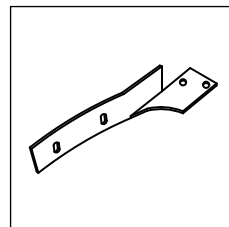

**31 15 00 85**

Suporte central 250 mm  
esquerdo

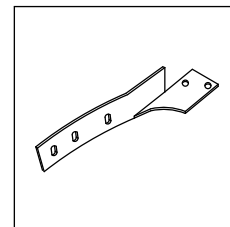

**31 15 00 86**

Suporte central 343 mm  
esquerdo

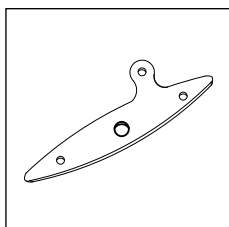

**31 15 01 01**

Topo lateral lâmina móvel  
120 mm

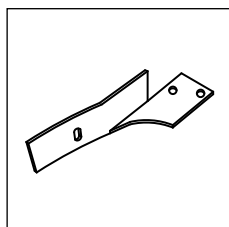

**31 15 01 08**

Suporte central 120 mm  
esquerdo

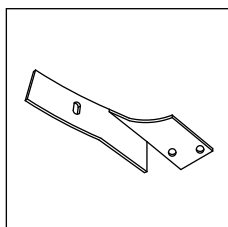

**31 15 01 09**

Suporte central 120 mm  
direito

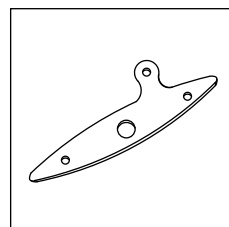

**31 15 01 12**

Topo lateral lâmina móvel  
250 mm

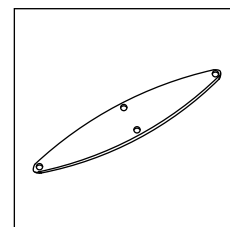

**31 15 01 15**

Topo simples 165 mm  
(Z-64)

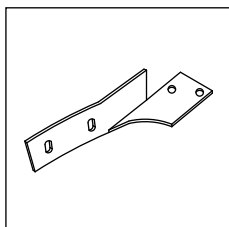

**31 15 01 16**

Suporte central 165 mm  
esquerdo

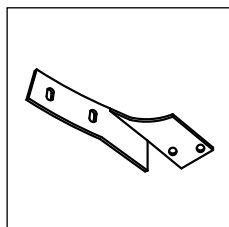

**31 15 01 17**

Suporte central 165 mm  
direito

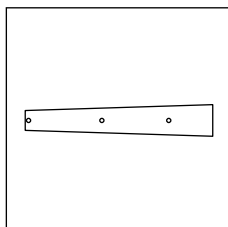

**31 15 01 35**

Topo para lâmina Z-67

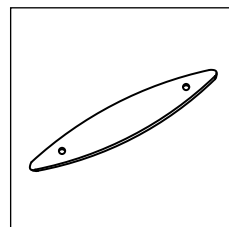

**31 15 01 36**

Topo simples 343 mm

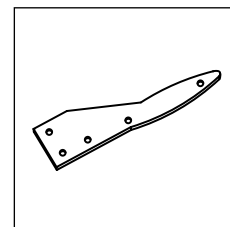

**31 15 01 40**

Topo fixação alongado  
343 mm

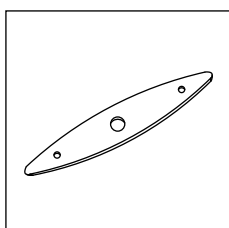

**31 15 01 42**

Topo lateral lâmina móvel  
120 mm

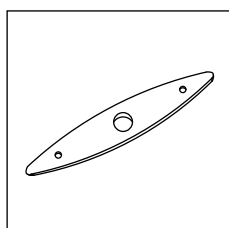

**31 15 01 43**

Topo lateral lâmina móvel  
343 mm

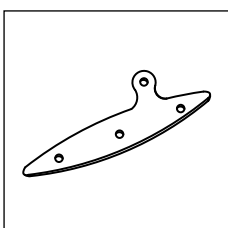

**31 15 01 44**

Topo lateral lâmina móvel  
343 mm

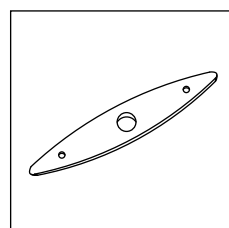

**31 15 01 46**

Topo lateral lâmina móvel  
250 mm

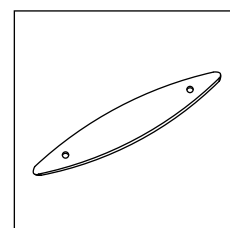

**31 15 01 51**

Topo simples 165 mm  
(Z-68)

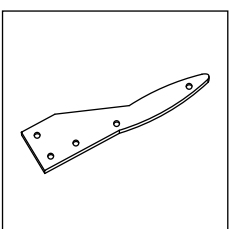

**31 15 01 56**

Topo fixação alongado  
165 mm (Z-68)

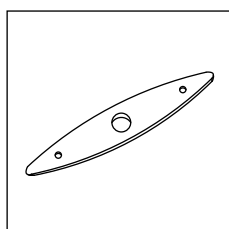

**31 15 01 60**

Topo lateral lâmina móvel  
165 mm (Z-68)

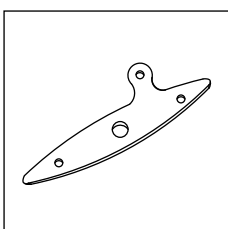

**31 15 01 61**

Topo lateral lâmina móvel  
com aba 165 mm (Z-68)

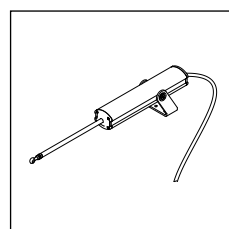

**31 15 10 84**

Motor eléctrico

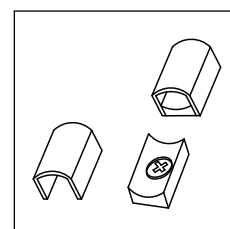

**31 15 11 00**

Presilha

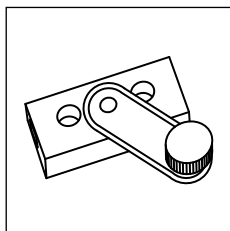

**31 15 11 02**

Manivela comando manual

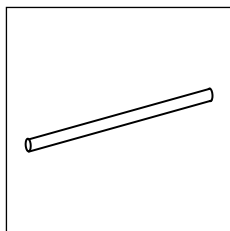

**31 15 11 03**

Tubo alumínio (3 mts)

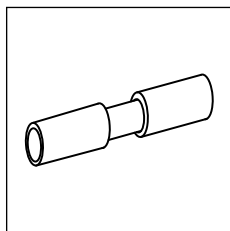

**31 15 11 04**

União de tubos

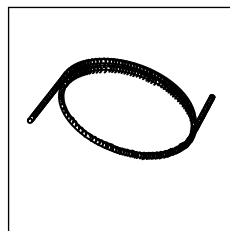

**31 15 11 12**

Bicha comando manual

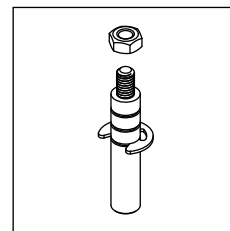

**31 15 11 24**

Eixo superior lâmina (Z-58 ou Z-68)

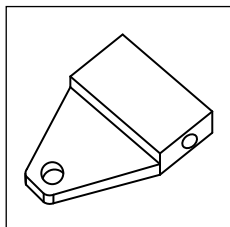

**31 15 11 25**

Ligação sistema eléctrico ou manual

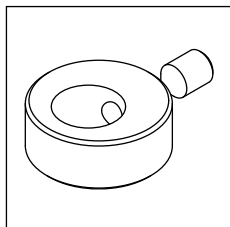

**31 15 11 26**

Anel freio lâmina (Z-58 ou Z-68)

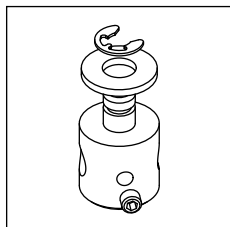

**31 15 11 28**

Eixo de ligação (Z-58 ou Z-68)

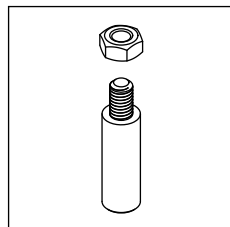

**31 15 11 29**

Eixo inferior (Z-58 ou Z-68)

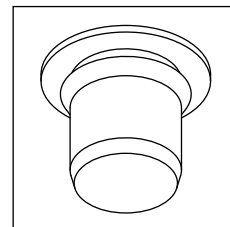

**31 15 11 30**

Casquilho inferior (Z-58 ou Z-68)

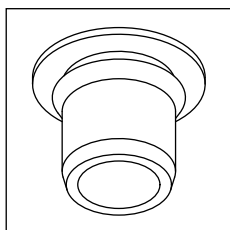

**31 15 11 31**

Casquilho superior (Z-58 ou Z-68)

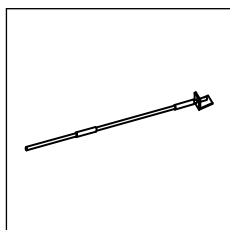

**31 15 11 36**

Accionador telescópico

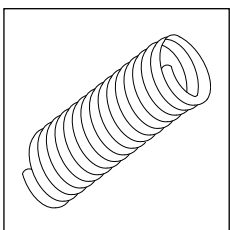

**31 15 11 96**

Mola fim de curso

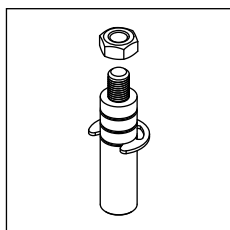

**31 15 12 24**

Eixo superior lâmina (Z-62 ou Z-65)

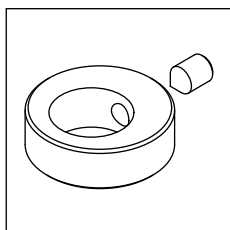

**31 15 12 26**

Anel freio lâmina (Z-62 ou Z-65)

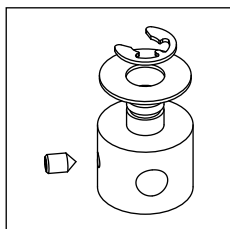

**31 15 12 28**

Eixo ligação lâmina (Z-62 ou Z-65)

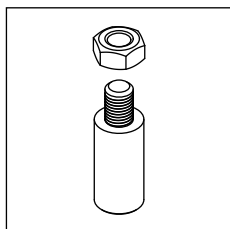

**31 15 12 29**

Eixo inferior lâmina (Z-62 ou Z-65)

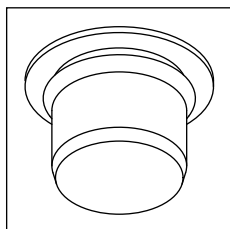

**31 15 12 30**

Casquilho inferior lâmina (Z-62 ou Z-65)

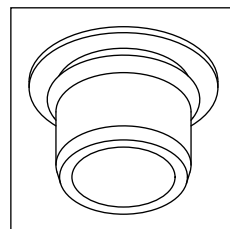

**31 15 12 31**

Casquilho superior lâmina (Z-62 ou Z-65)



**Z-58**

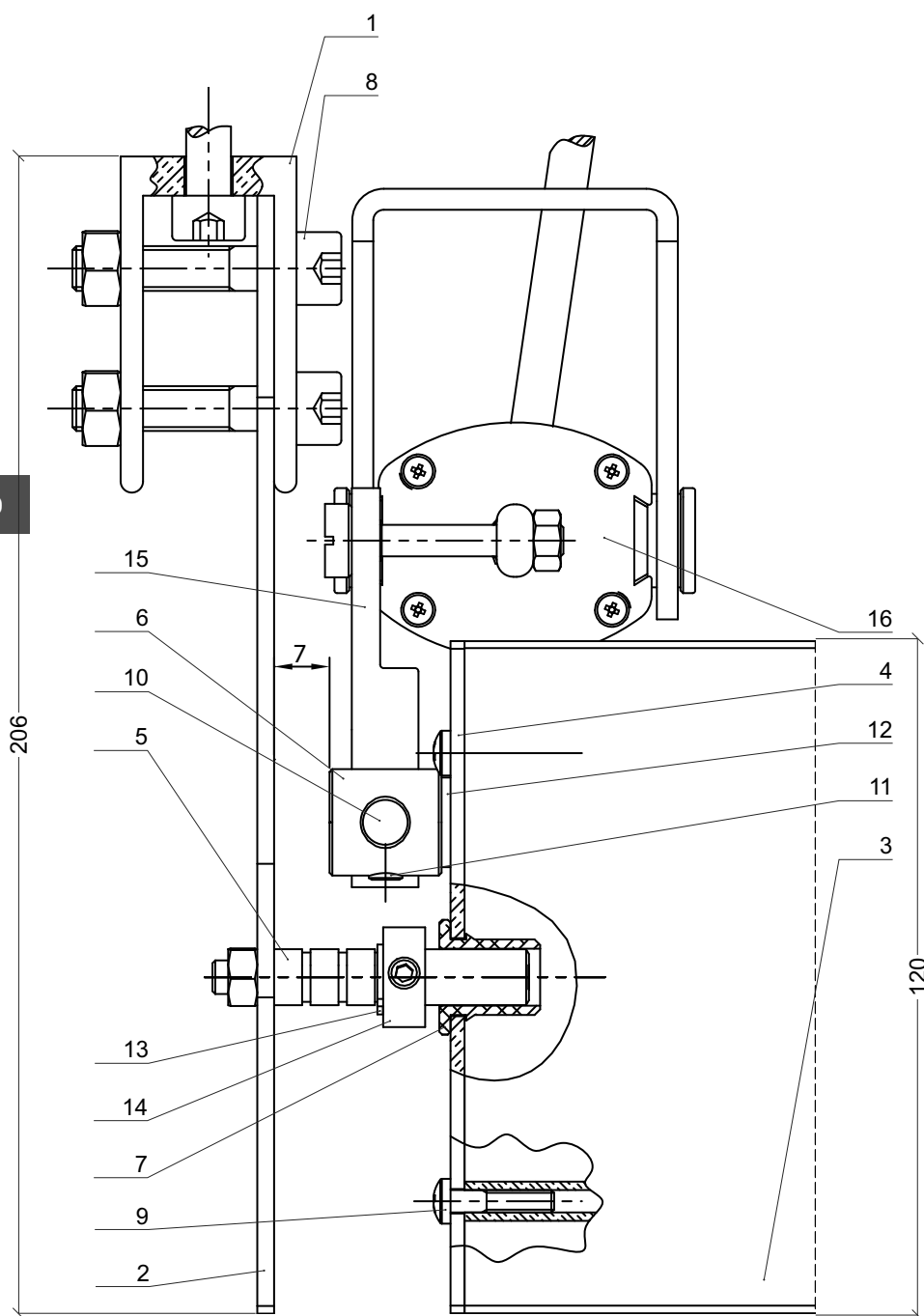

- 1 **U-09** (calha suporte U-09)
- 2 **31 15 00 71** (topo fixação alongado Z-58)
- 3 **Z-58** (lâmina 120 mm)
- 4 **31 15 01 01** (topo móvel)
- 5 **31 15 11 24** (eixo para móvel de rotação)
- 6 **31 15 11 28** (eixo de ligação lâmina)
- 7 **31 15 11 31** (casquilho em nylon para eixo)
- 8 **Parafuso DIN 912 M8x40**
- 9 **Parafuso ISO 7045 M4x16**
- 10 **G-01** (varão 8 mm)
- 11 **Perno DIN 913 M6x6**
- 12 **Anilha em nylon 16x1.6**
- 13 **Freio TRUARC**
- 14 **31 15 11 26** (anel excêntrico de ajustamento)
- 15 **31 15 11 25** (ligação ao motor/comando manual)
- 16 **31 15 10 84** (motor eléctrico)

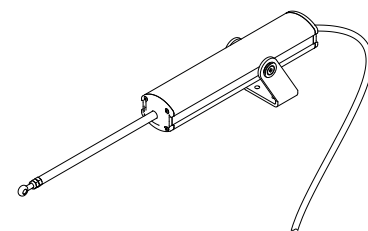

Montagem do motor sempre com o pistão virado para baixo



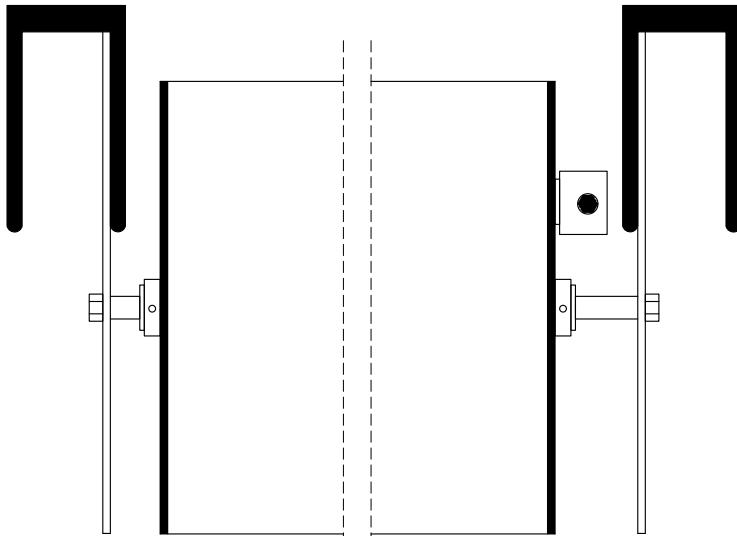

Secção B - B

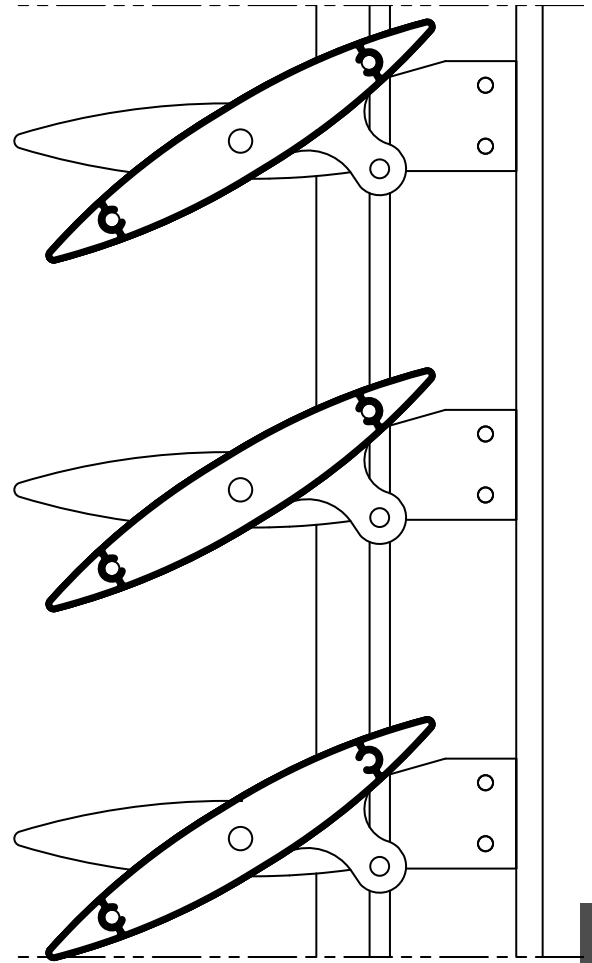
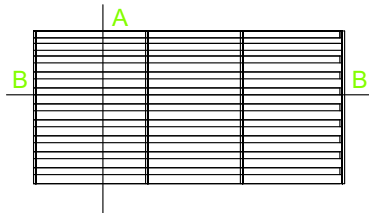

Secção A - A

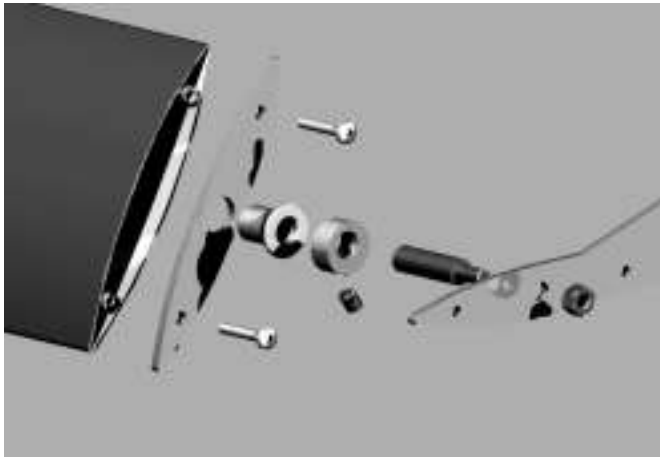

- 1 **U-09** (calha suporte U-09)
- 2 **31 15 00 79** (topo fixação alongado 250 mm)
- 3 **Z-62** (lâmina 250 mm)
- 4 **31 15 01 12** (topo móvel)
- 5 **31 15 12 24** (eixo para móvel de rotação)
- 6 **31 15 12 28** (eixo de ligação lâmina)
- 7 **31 15 12 31** (casquilho em nylon para eixo)
- 8 **Parafuso DIN 912 M8x40**
- 9 **Parafuso ISO 7045 M4x16**
- 10 **G-01** (varão 8 mm)
- 11 **Perno DIN 913 M6x6**
- 12 **Anilha em nylon 16x1.6**
- 13 **Freio TRUARC**
- 14 **31 15 11 26** (anel excêntrico de ajustamento)
- 15 **31 15 11 25** (ligação ao motor/comando manual)
- 16 **31 15 10 84** (motor eléctrico)

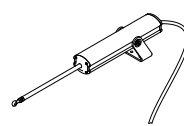
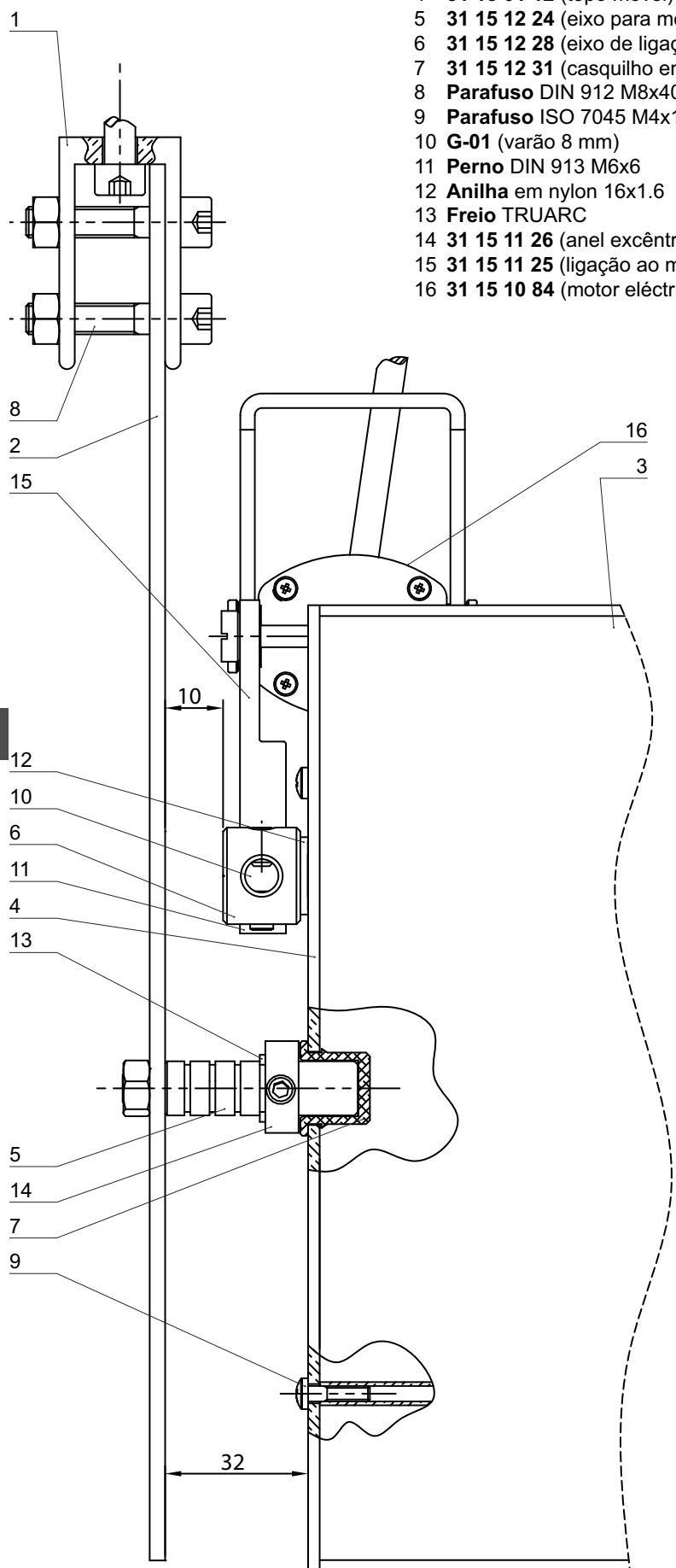

Montagem do motor sempre com o pistão virado para baixo

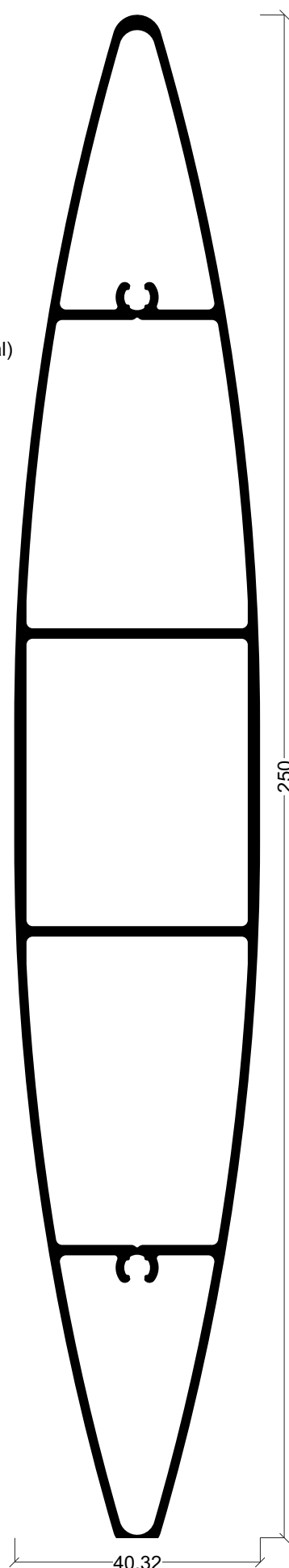

**Z-62**

